

Quartz Crystal Oscillators

One of the most important features of any oscillator is its *frequency stability*, or in other words its ability to provide a constant frequency output under varying load conditions.

Some of the factors that affect the frequency stability of an oscillator generally include: variations in temperature, variations in the load, as well as changes to its DC power supply voltage to name a few.

Frequency stability of the output signal can be greatly improved by the proper selection of the components used for the resonant feedback circuit, including the amplifier. But there is a limit to the stability that can be obtained from normal LC and RC tank circuits.

To obtain a very high level of oscillator stability a **Quartz Crystal** is generally used as the frequency determining device to produce another types of oscillator circuit known generally as a **Quartz Crystal Oscillator**, (XO).

When a voltage source is applied to a small thin piece of quartz crystal, it begins to change shape producing a characteristic known as the **Piezo-electric effect**. This Piezo-electric Effect is the property of a crystal by which an electrical charge produces a mechanical force by changing the shape of the crystal and vice versa, a mechanical force applied to the crystal produces an electrical charge.



Quartz Crystal Oscillator

Then, piezo-electric devices can be classed as Transducers as they convert energy of one kind into energy of another (electrical to mechanical or mechanical to electrical). This piezo-electric

effect produces mechanical vibrations or oscillations which can be used to replace the
our use of cookies. More info



standard LC tank circuit in the previous oscillators.

There are many different types of crystal substances that can be used as oscillators with the most important of these for electronic circuits being the quartz minerals, due in part to their greater mechanical strength.

The quartz crystal used in a **Quartz Crystal Oscillator** is a very small, thin piece or wafer of cut quartz with the two parallel surfaces metallised to make the required electrical connections. The physical size and thickness of a piece of quartz crystal is tightly controlled since it affects the final or fundamental frequency of oscillations. The fundamental frequency is generally called the crystals “characteristic frequency”.

Once cut and shaped, the crystal can not be used at any other frequency. In other words, its size and shape determines its fundamental oscillation frequency.

The crystals characteristic or characteristic frequency is inversely proportional to its physical thickness between the two metallised surfaces. A mechanically vibrating crystal can be represented by an equivalent electrical circuit consisting of low resistance R , a large inductance L and small capacitance C as shown below.

Quartz Crystal Equivalent Model

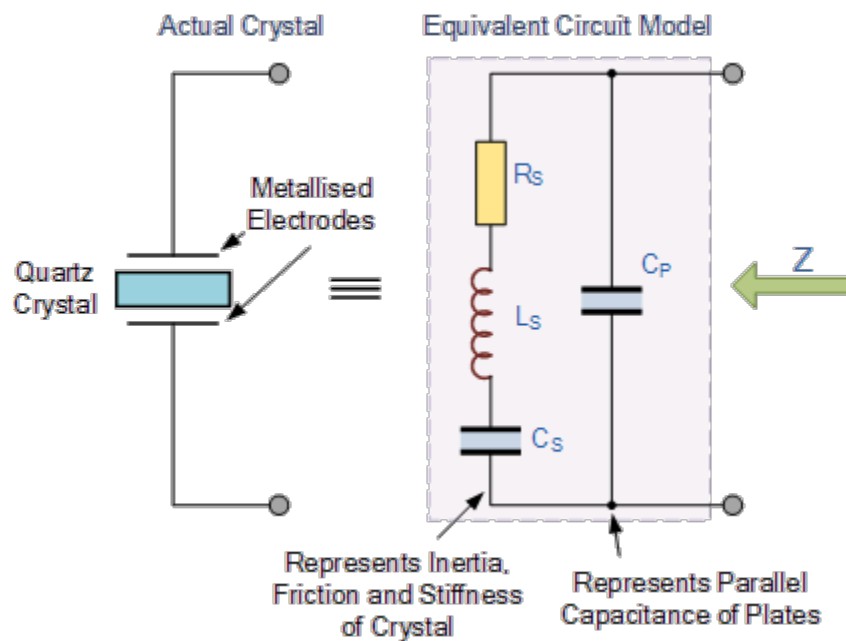

The equivalent electrical circuit for the quartz crystal shows a series RLC circuit, which represents the mechanical vibrations of the crystal, in parallel with a capacitance, C_p which

we use cookies to enhance your experience. By continuing to visit this site you agree to our use of cookies. More info

The equivalent impedance of the crystal has a series resonance where C_s resonates with inductance, L_s at the crystals operating frequency. This frequency is called the crystals series frequency, f_s . As well as this series frequency, there is a second frequency point established as a result of the parallel resonance created when L_s and C_s resonates with the parallel capacitor C_p as shown.

Crystal Impedance against Frequency

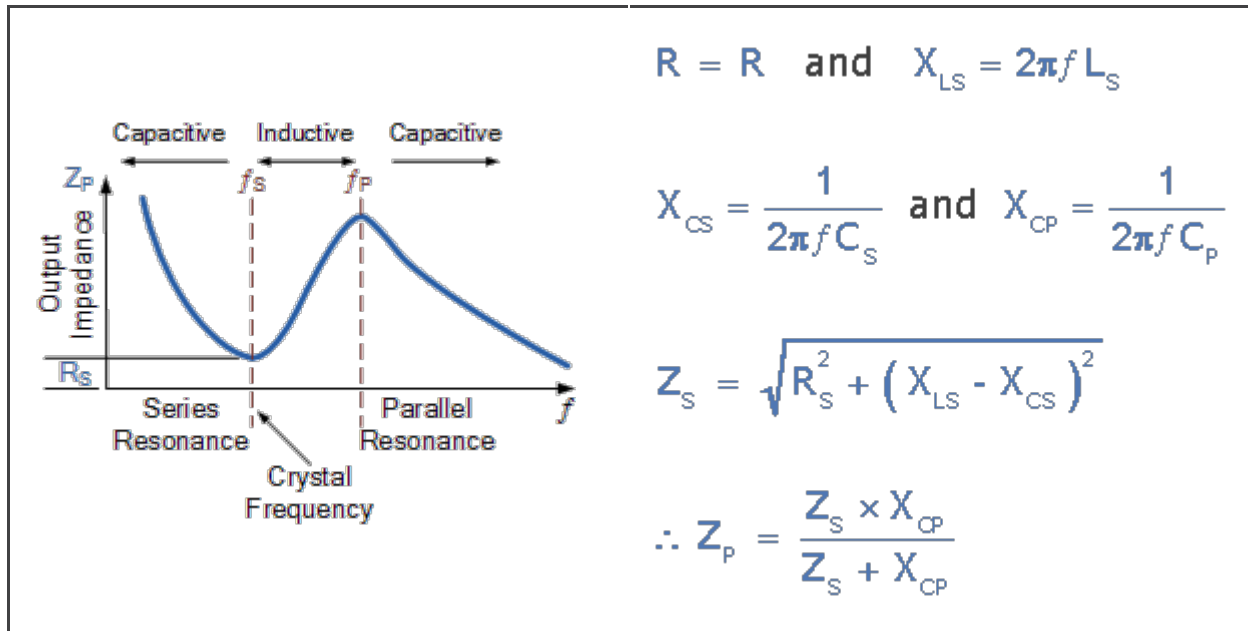

The slope of the crystals impedance above shows that as the frequency increases across its terminals. At a particular frequency, the interaction of between the series capacitor C_s and the inductor L_s creates a series resonance circuit reducing the crystals impedance to a minimum and equal to R_s . This frequency point is called the crystals series resonant frequency f_s and below f_s the crystal is capacitive.

As the frequency increases above this series resonance point, the crystal behaves like an inductor until the frequency reaches its parallel resonant frequency f_p . At this frequency point the interaction between the series inductor, L_s and parallel capacitor, C_p creates a parallel tuned LC tank circuit and as such the impedance across the crystal reaches its maximum value.

Then we can see that a quartz crystal is a combination of a series and parallel tuned resonance circuits, oscillating at two different frequencies with the very small difference between the two depending upon the cut of the crystal. Also, since the crystal can operate at either its

series or parallel resonance frequencies, a crystal oscillator circuit needs to be tuned to one or the other frequency as you can see from both together.

So depending upon the circuit characteristics, a quartz crystal can act as either a capacitor, an inductor, a series resonance circuit or as a parallel resonance circuit and to demonstrate this more clearly, we can also plot the crystals reactance against frequency as shown.

Crystal Reactance against Frequency

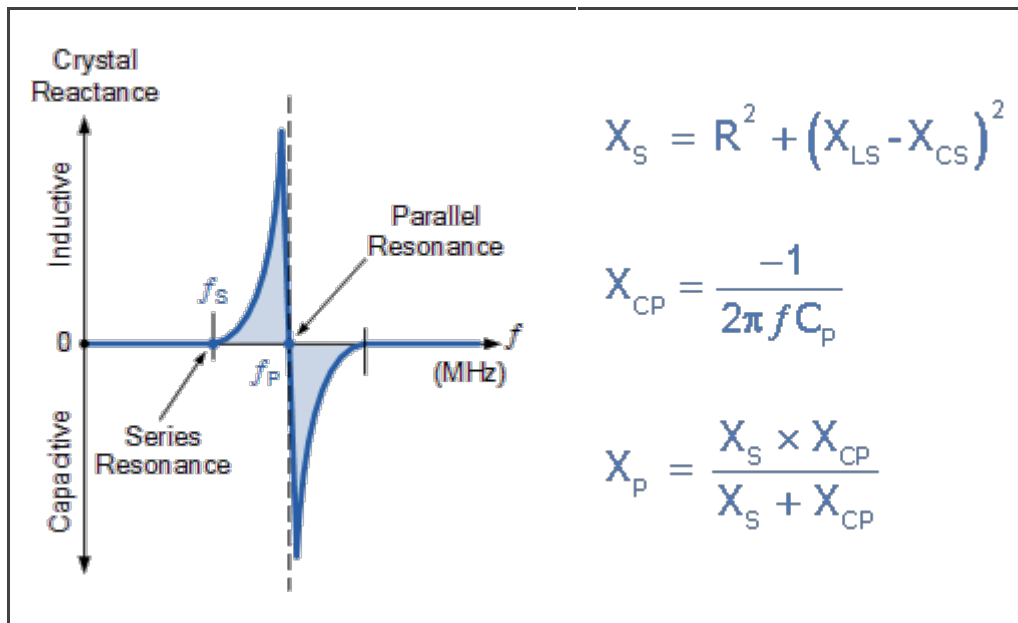

The slope of the reactance against frequency above, shows that the series reactance at frequency f_s is inversely proportional to C_s because below f_s and above f_p the crystal appears capacitive. Between frequencies f_s and f_p , the crystal appears inductive as the two parallel capacitances cancel out.

Then the formula for the crystals series resonance frequency, f_s is given as:

Series Resonant Frequency

$$f_s = \frac{1}{2\pi\sqrt{L_s C_s}}$$

The parallel resonance frequency, f_p occurs when the reactance of the series LC leg equals the reactance of the parallel capacitor, C_p and is given as:

Parallel Resonant Frequency

$$f_p = \frac{1}{2\pi \sqrt{L_s \left(\frac{C_p C_s}{C_p + C_s} \right)}}$$

Quartz Crystal Oscillator Example No1

A quartz crystal has the following values: $R_s = 6.4\Omega$, $C_s = 0.09972\text{pF}$ and $L_s = 2.546\text{mH}$. If the capacitance across its terminal, C_p is measured at 28.68pF , Calculate the fundamental oscillating frequency of the crystal and its secondary resonance frequency.

The crystals series resonant frequency, f_s

$$f_s = \frac{1}{2\pi \sqrt{L_s C_s}} = \frac{1}{2\pi \sqrt{2.546\text{mH} \times 0.09972\text{pF}}}$$

$$f_s = \frac{1}{2\pi \sqrt{0.002546 \times 99.72 \times 10^{-15}}} = 9.987\text{MHz}$$

The crystal's parallel resonant frequency, f_p

$$f_p = \frac{1}{2\pi \sqrt{L_s \left(\frac{C_p C_s}{C_p + C_s} \right)}}$$

$$f_p = \frac{1}{2\pi \sqrt{2.546\text{mH} \left(\frac{28.68\text{pF} \times 0.09972\text{pF}}{28.68\text{pF} + 0.09972\text{pF}} \right)}}$$

$$f_p = 10,004,996\text{Hz or } 10.005\text{MHz}$$

We can see that the difference between f_s , the crystal's fundamental frequency and f_p is small at about 18kHz ($10.005\text{MHz} - 9.987\text{MHz}$). However during this frequency range, the Q-factor (Quality Factor) of the crystal is extremely high because the inductance of the crystal

is much higher than its capacitive or resistive values. The Q-factor of our crystal at the series resonance frequency is given as:

Crystal Oscillators Q-factor

$$Q = \frac{X_L}{R} = \frac{2\pi fL}{R} = \frac{2\pi \times 9.987 \times 10^6 \times 0.002546}{6.4}$$

$$Q = 24966 \text{ or } 25,000$$

Then the Q-factor of our crystal example, about 25,000, is because of this high X_L/R ratio. The Q-factor of most crystals is in the area of 20,000 to 200,000 as compared to a good LC tuned tank circuit we looked at earlier which will be much less than 1,000. This high Q-factor value also contributes to a greater frequency stability of the crystal at its operating frequency making it ideal to construct crystal oscillator circuits.

So we have seen that a quartz crystal has a resonant frequency similar to that of a electrically tuned LC tank circuit but with a much higher Q factor. This is due mainly to its low series resistance, R_s . As a result, quartz crystals make an excellent component choice for use in oscillators especially very high frequency oscillators.

Typical crystal oscillators can range in oscillation frequencies from about 40kHz to well over 100MHz depending upon their circuit configuration and the amplifying device used. The cut of the crystal also determines how it will behave as some crystals will vibrate at more than one frequency, producing additional oscillations called overtones.

Also, if the crystal is not of a parallel or uniform thickness it may have two or more resonant frequencies both with a fundamental frequency producing what are called and harmonics, such as second or third harmonics.

Generally though the fundamental oscillating frequency for a quartz crystal is much more stronger or pronounced than that of and secondary harmonics around it so this would be the one used. We have seen in the graphs above that a crystals equivalent circuit has three reactive components, two capacitors plus an inductor so there are two resonant frequencies, the lowest is a series resonant frequency and the highest is the parallel resonant frequency.

We have seen in the previous tutorials, that an amplifier circuit will oscillate if it has a loop gain greater or equal to one and the feedback is positive. In a Quartz Crystal Oscillator circuit the

oscillator will oscillate at the crystals fundamental parallel resonant frequency as the crystal always wants to oscillate when a voltage source is applied to it.

However, it is also possible to “tune” a crystal oscillator to any even harmonic of the fundamental frequency, (2nd, 4th, 8th etc.) and these are known generally as **Harmonic Oscillators** while **Overtone Oscillators** vibrate at odd multiples of the fundamental frequency, (3rd, 5th, 11th etc). Generally, crystal oscillators that operate at overtone frequencies do so using their series resonant frequency.

Colpitts Quartz Crystal Oscillator

Crystal oscillator circuits are generally constructed using bipolar transistors or FETs. This is because although operational amplifiers can be used in many different low frequency ($\leq 100\text{kHz}$) oscillator circuits, operational amplifiers just do not have the bandwidth to operate successfully at the higher frequencies suited to crystals above 1MHz.

The design of a **Crystal Oscillator** is very similar to the design of the Colpitts Oscillator we looked at in the previous tutorial, except that the LC tank circuit that provides the feedback oscillations has been replaced by a quartz crystal as shown below.

Colpitts Crystal Oscillator

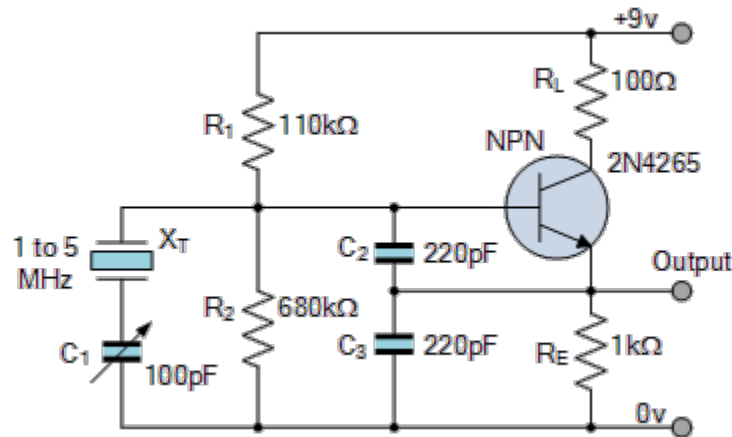

This type of **Crystal Oscillators** are designed around a common collector (emitter-follower) amplifier. The R_1 and R_2 resistor network sets the DC bias level on the Base while emitter resistor R_E sets the output voltage level. Resistor R_2 is set as large as possible to prevent loading to the parallel connected crystal.

The transistor, a 2N4265 is a general purpose NPN transistor connected in a common

well above the crystal's fundamental frequency which can be between about 1MHz and 5MHz.

The circuit diagram above of the **Colpitts Crystal Oscillator** circuit shows that capacitors, C1 and C2 shunt the output of the transistor which reduces the feedback signal. Therefore, the gain of the transistor limits the maximum values of C1 and C2. The output amplitude should be kept low in order to avoid excessive power dissipation in the crystal otherwise could destroy itself by excessive vibration.

Pierce Oscillator

Another common design of the quartz crystal oscillator is that of the **Pierce Oscillator**. The Pierce oscillator is very similar in design to the previous Colpitts oscillator and is well suited for implementing crystal oscillator circuits using a crystal as part of its feedback circuit.

The Pierce oscillator is primarily a series resonant tuned circuit (unlike the parallel resonant circuit of the Colpitts oscillator) which uses a JFET for its main amplifying device as FET's provide very high input impedances with the crystal connected between the Drain and Gate via capacitor C1 as shown below.

Pierce Crystal Oscillator

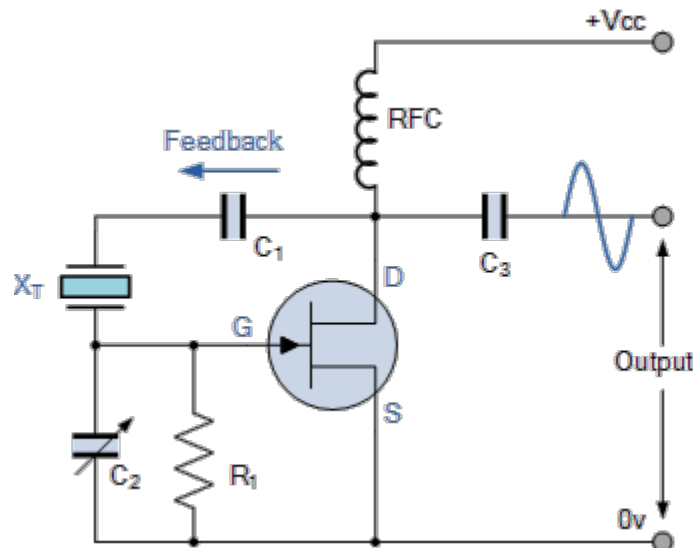

In this simple circuit, the crystal determines the frequency of oscillations and operates at its series resonant frequency, f_s giving a low impedance path between the output and the input. There is a 180° phase shift at resonance, making the feedback positive. The amplitude of the output sine wave is limited to the maximum voltage range at the Drain terminal.

radio frequency choke, RFC reverses during each cycle. Most digital clocks, watches and timers use a Pierce Oscillator in some form or other as it can be implemented using the minimum of components.

As well as using transistors and FETs, we can also create a simple basic parallel-resonant crystal oscillator similar in operation to the Pierce oscillator by using a CMOS inverter as the gain element. The basic quartz crystal oscillator consists of a single inverting Schmitt trigger logic gate such as the TTL 74HC19 or the CMOS 40106, 4049 types, an inductive crystal and two capacitors. These two capacitors determine the value of the crystals load capacitance. The series resistor helps limit the drive current in the crystal and also isolates the inverters output from the complex impedance formed by capacitor-crystal network.

CMOS Crystal Oscillator

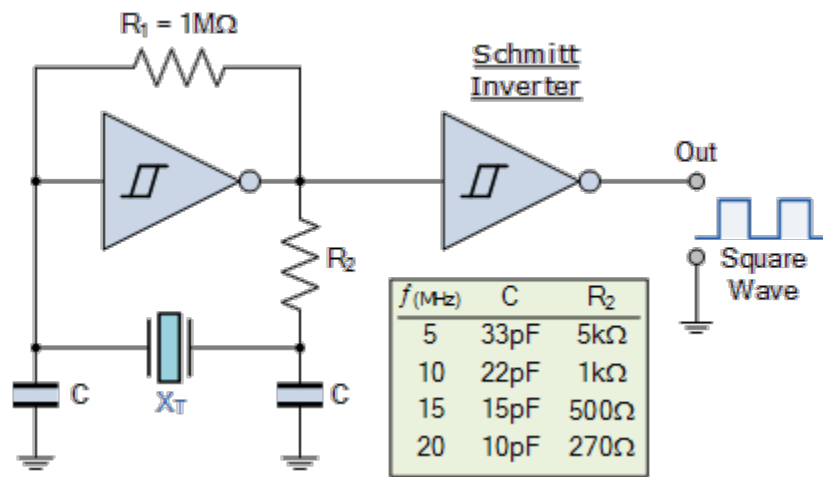

The crystal oscillates at its series resonance frequency. The CMOS inverter is initially biased into the middle of its operating region by the feedback resistor, R1. This ensures that the Q-point of the inverter is in a region of high gain. Here a 1MΩ value resistor is used, but its value is not critical as long as it is more than 1MΩ. An additional inverter is used to buffer the output from the oscillator to the connected load.

The inverter provides 180° of phase shift and the crystal capacitor network the additional 180° required for oscillation. The advantage of the CMOS crystal oscillator is that it will always automatically readjust itself to maintain this 360° phase shift for oscillation.

Unlike the previous transistor based crystal oscillators which produced a sinusoidal output waveform, as the CMOS Inverter oscillator uses digital logic gates, the output is a square wave oscillating between HIGH and LOW. Naturally, the maximum operating frequency depends upon the switching characteristics of the logic gate used.

Microprocessor Crystal Quartz Clocks

We can not finish a **Quartz Crystal Oscillators** tutorial without mentioning something about Microprocessor crystal clocks. Virtually all microprocessors, micro-controllers, PICs and CPU's generally operate using a *Quartz Crystal Oscillator* as its frequency determining device to generate their clock waveform because as we already know, crystal oscillators provide the highest accuracy and frequency stability compared to resistor-capacitor, (RC) or inductor-capacitor, (LC) oscillators.

The CPU clock dictates how fast the processor can run and process the data with a microprocessor, PIC or micro-controller having a clock speed of 1MHz means that it can process data internally one million times per second at every clock cycle. Generally all that's needed to produce a microprocessor clock waveform is a crystal and two ceramic capacitors of values ranging between 15 to 33pF as shown below.

Microprocessor Oscillator

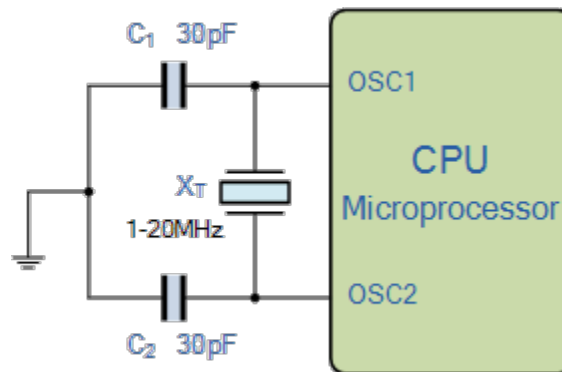

Most microprocessors, micro-controllers and PIC's have two oscillator pins labelled OSC1 and OSC2 to connect to an external quartz crystal circuit, standard RC oscillator network or even a ceramic resonator. In this type of microprocessor application the **Quartz Crystal Oscillator** produces a train of continuous square wave pulses whose fundamental frequency is controlled by the crystal itself. This fundamental frequency regulates the flow of instructions that controls the processor device. For example, the master clock and system timing.

Quartz Crystal Oscillator Example No2

A quartz crystal has the following values after being cut, $R_s = 1k\Omega$, $C_s = 0.05pF$, $L_s = 3H$ and $C_p = 10pF$. Calculate the crystal's series and parallel oscillating frequencies.

The series oscillating frequency is given as:

$$f_s = \frac{1}{2\pi\sqrt{L_S C_S}} = \frac{1}{2\pi\sqrt{3 \times 0.05 \times 10^{-12}}}$$

$$\therefore f_s = 410883\text{Hz or } 411\text{kHz}$$

The parallel oscillating frequency is given as:

$$f_p = \frac{1}{2\pi\sqrt{L_S \left(\frac{C_P C_S}{C_P + C_S} \right)}} = \frac{1}{2\pi\sqrt{3 \left(\frac{10 \times 10^{-12} \times 0.05 \times 10^{-12}}{10 \times 10^{-12} + 0.05 \times 10^{-12}} \right)}}$$

$$\therefore f_p = 411910\text{Hz or } 412\text{kHz}$$

Then the frequency of oscillation for the crystal will be between 411kHz and 412kHz.