



SurvivalRing

Study Yesterday... Prepare Today... Live Tomorrow

This digital document created and presented by Richard Fleetwood. He is the founder, author, producer, and webmaster of the **SurvivalRing** (<http://www.survivalring.org>) and **Civil Defense Now!** (<http://www.survivalring.org/cd-main.htm>) websites.

SurvivalRing has as its goal the ideal of being the leading source of survival, preparedness, and self reliance information on the Internet. Linkage, assistance, and creation of digital content in areas that until now have only been hinted at or impossible to find, is being added to everyday via the SurvivalRing website and email lists.

Thousands of hours of searching, writing, and communications have been spent collecting over 2 gigabytes of digital content, as well as tens of thousands of pages of hard copy original public domain material in the areas of civil defense, survival, training, and preparedness, from all over the globe.

As much as possible is being put online at his website at
<http://www.survivalring.org>

Civil Defense Now!

Part of The SurvivalRing website

The content of THIS file, while created from PUBLIC DOMAIN material, produced by the U.S. (or other) Government at taxpayer expense, is presented in THIS digital format, produced from the ORIGINAL hardcopy document, for the benefit of all mankind, in hoping to help spread the idea of PREPAREDNESS for any and all threats that may come from either natural, extraterrestrial (space based), or manmade sources.

There are too many situations and incidents that can come to pass in everyday life, that when time is taken to learn and skills obtained, can mean the difference between life and death. Sept. 11, 2001 proved to the world that no matter how safe a person thinks they may be, death and injury can come from the most UN-LIKELY place, at any time. The documents presented in this series of digitized works, can help the average person with the knowledge within, to know how to save those persons closest to them in REAL disaster. Help spread this idea of sharing SURVIVAL INFORMATION.

If you have documents from any era, on any disaster or civil defense area, PLEASE contact Richard at his email address of **RAFLEET@AOL.COM**. Check the website for the LATEST additions to the CIVIL DEFENSE NOW online library archive. All data online, and much more, is also available on CD-ROM. Information is available at the website on how to obtain it. Thanks for your support, and enjoy the information contained on the following pages. Share them with those who will learn from them and teach what they know to others.

Donations of U.S. or other civil defense documents, articles, books, videos, digitized ephemera, patches, tools, photos, or anything of this nature is appreciated, as well as cash gifts or donations to support the website costs and bills. Address information is available on the homepage of Civil Defense Now! (URL located above)

- Richard Fleetwood – January 2002 — ALL RIGHTS RESERVED –

This document may NOT be reproduced commercially on any media WITHOUT EXPRESSLY WRITTEN permission from the creator of this digital presentation. Educational Institutions MAY use this material in any way needed.

Permission granted to individuals for PERSONAL USE ONLY.

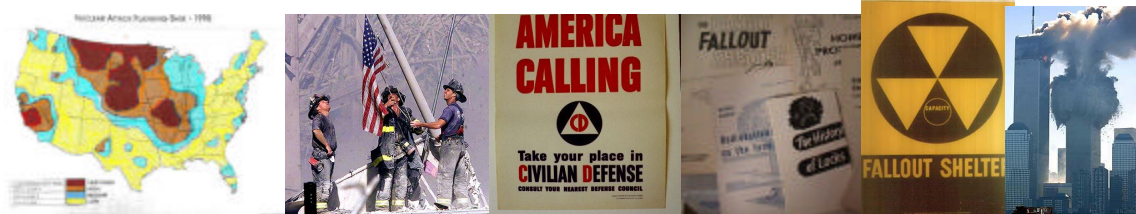









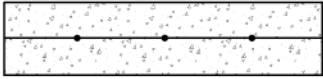
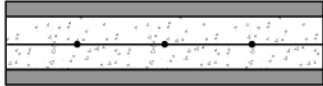
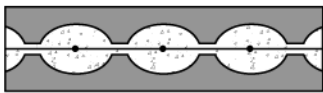

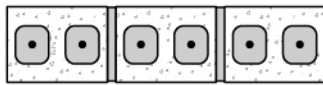

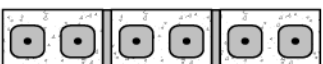

Appendix E

Wall Sections That Passed the Missile Impact Tests

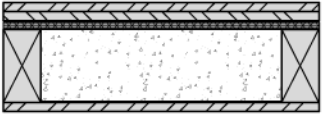
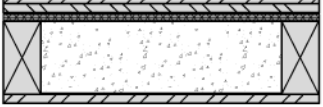
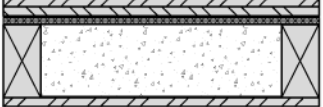

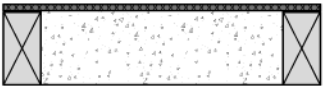
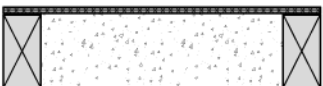
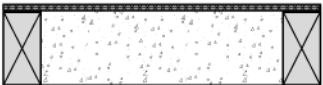
The following sheets document the performance of wall sections that passed the missile impact tests. The following information is provided for each wall section: description of the wall construction (e.g., stud wall with plywood and/or metal sheathing, stud wall with concrete infill, reinforced CMU wall, ICF wall), cross-section illustration, test missile speed, and description of damage.

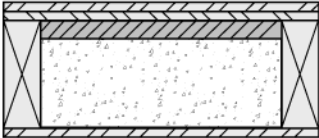
Type of Wall Section (Target)	Description of Wall Section	Missile Speed (mph)	Description of Damage
Reinforced concrete wall, at least 6 in. thick, reinforced with #4 rebar every 12 in. (both vertically and horizontally)		100+	The target has been proven successful in previous tests.
Insulating concrete form (ICF) flat wall section at least 4" thick reinforced with #4 rebar every 12 in. (both vertically and horizontally)		100+	The target has been proven successful in previous tests.
Insulating concrete form (ICF) waffle grid wall section at least 6 in. thick reinforced with #5 rebar every 12 in. vertically and #4 rebar every 16 in. horizontally		100+	The target has been proven successful in previous tests.
Brick cavity wall reinforced with #4 rebar every 12 in. and concrete infill		100+	The target has been proven successful in previous tests.
8 in. CMU reinforced with concrete and #4 rebar in every cell		100+	The target was impacted over 30 times with the design missile. This was done for demonstration purposes. Only the first (verification) test was conducted as part of G&O contract.
6 in. CMU reinforced with concrete and #4 rebar in every cell		106.7	No damage was visible. 1/8 to 3/16 in. indentation on impact side.
6 in. CMU reinforced with concrete and #4 rebar in every cell		103.4	The missile impacted the target at a mortar joint. The target was cracked from the point of impact to the top of the target both in the front and in the back. The mortar spalled out of the joint on the back of the target.
6 in. CMU reinforced with concrete and #4 rebar in every cell		97.0	This target was tested previously. The second missile impacted the target in the same place as the first. The existing crack was extended into the base. A new crack appeared in the next joint 8 in. away and extended to the top of the target. The missile perforated the target and spalled the concrete fill out of the back of the target.

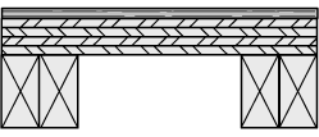
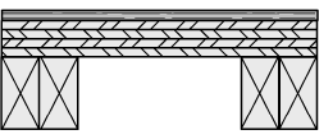
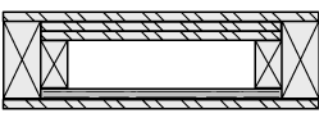
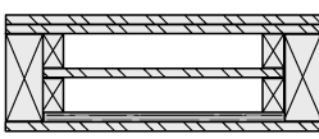
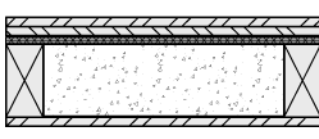
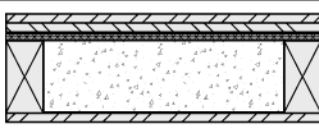
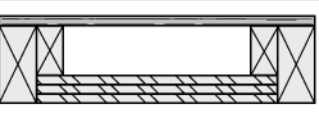
Type of Wall Section (Target)	Description of Wall Section	Missile Speed (mph)	Description of Damage
6 in. CMU reinforced with concrete and #4 rebar in every cell		No Time	No penetration of the target occurred. The target was cracked from the point of impact to the top of the target.
6 in. CMU reinforced with concrete and #4 rebar in every cell		111.3	The target was impacted at a vertical mortar joint. There was a 1/16 in. indentation on the impact face but no visible damage to either side of the target.
6 in. CMU reinforced with concrete and #4 rebar in every cell		106.9	The target was impacted at a vertical mortar joint. There was a 1/16 in. indentation on the impact face. The joint spalled slightly on the non-impact side. A small crack was detected at the impact point terminating at the top of the target.
2x4 stud wall with CD grade plywood, 14 ga. 1/2 in. expanded metal, and concrete infill		105.0	The missile impacted 4 in. to the left of a stud. No damage was visible on the back of the target.
2x4 stud wall with CD grade plywood, 14 ga. 1/2 in. expanded metal, and concrete infill		106.1	The missile impacted 1 1/2 in. to the left of a stud. No damage was visible on the back of the target.
2x4 stud wall with CD grade plywood, 14 ga. 1/2 in. expanded metal, and concrete infill		105.4	The missile impacted 1 in. to the right of a stud. No damage was visible on the back of the target.
2x4 stud wall filled with concrete with no plywood and 14 ga. 1/2 in. expanded metal on the non-impact face		107.7	The missile made partial contact with the stud. The concrete was cracked around the impact area.
2x4 stud wall filled with concrete with no plywood and 14 ga. 1/2 in. expanded metal on the non-impact face		107.2	The missile made partial contact with the stud. The concrete was severely damaged, and a 4 in. deflection on the back of the target was observed.
2x4 stud wall filled with concrete with no plywood and 14 ga. 1/2 in. expanded metal on the non-impact face		107.1	The missile impacted the concrete. No damage was visible.
2x4 stud wall filled with concrete with no plywood and 14 ga. 1/2 in. expanded metal on the non-impact face		104.5	The missile hit the stud fully. There was 3 in. of deflection to the back of the target but no perforation.

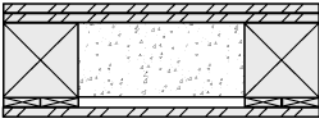
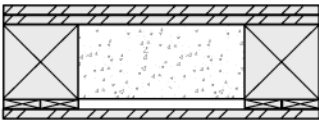
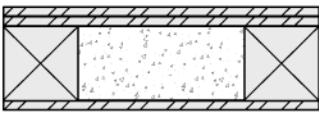
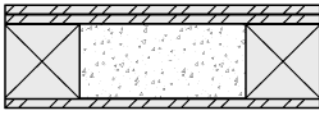
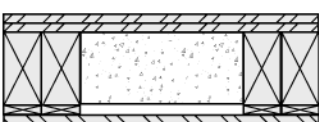
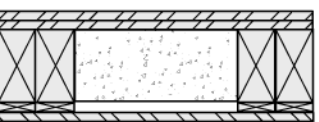
Type of Wall Section (Target)	Description of Wall Section	Missile Speed (mph)	Description of Damage
4 in. concrete block in a 2x6 stud wall with 1½ in. of polystyrene between block and two layers of ¾ in. CD grade plywood.		111.3	The missile penetrated the target. There was no visible damage to the back side of the target.
Double 2x4 stud wall with 4 layers of ¾ in. CD grade plywood and 14 ga. steel on the back face		104-107	1 in. of deformation on the back face of the steel.
Double 2x4 stud wall with 4 layers of ¾ in. CD grade plywood and 14 ga. steel on the back face		106.6	The target was impacted next to a stud. Several heads of screws were popped off the back of the target. The steel had 1 in. of deformation.
Double 2x4 stud wall with 4 layers of ¾ in. CD grade plywood and 14 ga. steel on the back face		104.9	The target was impacted on the stud line. The stud was cut in two. No deformation was visible on the back side
4 layers of ¾ in. plywood with 14 ga. steel insert with spacers between the insert and the back face		109.4	The missile penetrated the target 1½-2 in. A crack in the plywood on the back face caused bending, but total separation did not occur.
14 ga. steel insert with spacers between all the inserts; the back face has two layers of ¾ in. CD grade plywood		108-110	The missile penetrated the target 1½-2 in. There was a crack in the plywood on the back face caused by bending, but total separation did not occur.
4 in. concrete block in a 2x4 stud wall with two layers of ¾ in. CD grade plywood and one layer of 14 ga. ½ in. expanded metal on the non-impact side and one layer of plywood on the impact side		106.7	¾ in. of penetration. There was no visible damage to the non-impact side.
4 in. concrete block in a 2x4 stud wall with two layers of ¾ in. CD grade plywood and one layer of 14 ga. ½ in. expanded metal on the non-impact side and one layer of plywood on the impact side		106.1	The missile impacted the stud and sheared it in two. There was no visible damage to the non-impact side.
2x4 stud wall with 3 layers of ¾ in. CD grade plywood inserts with 14 ga. metal on the non-impact side		105.7	The first insert of plywood failed in shear while the interior two failed in bending. The studs started to be torn in half, and there was 3 in. of deformation of the 14 ga. metal.

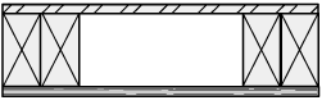
Type of Wall Section (Target)	Description of Wall Section	Missile Speed (mph)	Description of Damage
4x4 stud wall with 1x4's on the studs, containing 4 in. concrete block, gypsum board infill, and one layer of 3/4 in. CD grade plywood on the impact face and two layers on the non-impact face		111.2	The missile impacted the stud, and 1/2 in. of deflection occurred on the non-impact side.
4x4 stud wall with 1x4's on the studs, containing 4 in. concrete block, gypsum board infill, and one layer of 3/4 in. CD grade plywood on the impact face and two layers on the non-impact side		106.5	Missile penetrated the target, but did not perforate the target when it impacted at the interface between the block and the 4x4 stud.
4x4 stud wall, containing 4 in. concrete block, with one layer of 3/8 in. CD grade plywood on the impact face and two layers of 3/4 in. CD grade plywood on the non-impact face		115.7	There was no missile penetration.
4x4 stud wall, containing 4 in. concrete block, with one layer of 3/8 in. CD grade plywood on the impact face and two layers of 3/4 in. CD grade plywood on the non-impact face		109.0	The missile impacted the interface between the block and the 4x4 stud, perforating the target 3 ft.
Double 2x4 stud wall with furring, containing 4 in. block, with two layers of 3/4 in. CD grade plywood on the non-impact face, one layer on the impact face, and a layer of 3/8 in. gyp. board on the impact face.		103	The missile impacted 1/2 in. on the stud and 1/2 in. on the concrete block infill. There was 1/2 in. of deformation on the non-impact side.
Double 2x4 stud wall with furring, containing 4 in. block, with two layers of 3/4 in. CD grade plywood on the non-impact face, one layer on the impact face, and a layer of 3/8 in. gyp. board on the impact face.		100.7	The missile impacted next to the stud. There was 1/2 in. of deformation and cracking on the non-impact side.

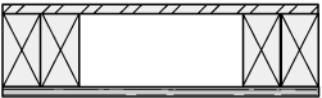
Type of Wall Section (Target)	Description of Wall Section	Missile Speed (mph)	Description of Damage
Double 2x4 stud wall with one layer of 12 ga. steel on the impact side and one layer of 3/4 in. CD grade plywood on the non-impact side.		No time	The missile impacted near the stud and was deflected.
Double 2x4 stud wall with one layer of 12 ga. steel on the impact side and one layer of 3/4 in. CD grade plywood on the non-impact side.		No Time	The missile impacted the stud and was deflected, there was some damage to the non-impact face.
Double 2x4 stud wall with one layer of 12 ga. steel on the impact side and one layer of 3/4 in. CD grade plywood on the non-impact side.		105.2	The missile impacted next to the stud and was destroyed.
Double 2x4 stud wall with one layer of 12 ga. steel on the impact side and one layer of 3/4 in. CD grade plywood on the non-impact side.		103.6	The missile impacted next to the stud and was destroyed.