

# Chapter 7

## MILITARY ANESTHESIA MACHINES

W. CLAYTON PETTY, M.D.\*

---

### INTRODUCTION

#### FIELD ANESTHESIA MACHINE MODEL 885A

Lower Case

Upper Case

Attaching the Medical Gas Supply

Pipeline Circuits

Flowmeters

Vaporizer

Breathing Circuit

Checkout and Maintenance

#### OHMEDA UNIVERSAL PORTABLE ANESTHESIA CIRCUIT

Specifications and Operation

Checkout and Maintenance

#### IDEAS FOR FUTURE MILITARY ANESTHESIA MACHINES

#### SUMMARY

*\*Captain, Medical Corps, U.S. Navy; formerly, Professor and Vice Chairman, Department of Anesthesiology, Uniformed Services University of the Health Sciences, 4301 Jones Bridge Road, Bethesda, Maryland 20814-4799; currently, Professor and Chairman, Department of Anesthesiology, Madigan Army Medical Center, Tacoma, Washington 98431-5000*

## INTRODUCTION

Anesthesia machines designed and manufactured for the U. S. military have had unique features since their inception during World War II. Prior to World War II, physicians, nurses, and dentists usually administered ether by an open-drop technique, which consisted of dripping it onto a face mask covered with two to four thin layers of cotton mesh (Figure 7-1). Until the Persian Gulf War, anesthesia machines in the field of combat were very similar to those used in civilian hospitals in the United States. During and after World War II, the first militarily specific anesthesia machines were sold. Chapter 31, *A Brief History of Military Anesthesia*, describes the milestones in the development of anesthesia machine Models 675 (manufactured by the former McKesson Appliance Co.), 685A, 685B, and 785 (manufactured by Ohio Chemical and Manufacturing Co., which is now owned by Ohmeda, Inc., Madison, Wis.), and the present Field Anesthesia Machine (FAM) Model 885A (manufactured by Ohmeda).

One of the major problems in the development of anesthesia machines for the military has been the lag time between the concept and the delivery of the product. Since the Korean War, not one anesthesia machine designed for civilian use has met the immediate needs of the U. S. military in combat. At the beginning of the Vietnam War, U.S. military hospitals in Vietnam delivered ether with the “pig” (Ohio 685A) anesthesia machine, which was designed immediately after World War II and used in the Korean War. In the Vietnam War, the FAM Model 785 was introduced but was immediately outmoded because halothane had been introduced while the 785 Model was being developed. The FAM Model 785 had a cyclopropane flowmeter (which rapidly became obsolete), and a large, in-circuit vaporizer for ether, but was unsafe for the delivery of halothane. Anesthesia providers overcame this problem by attaching a halothane single-agent, temperature-compensated vaporizer to the FAM 785; they buried all the cyclopropane tanks and used halothane as the major inhalational anesthetic (with the addition of nitrous oxide) for the remainder of the war. The FAM Model 885 was developed in the hiatus between the Vietnam War and the Persian Gulf War. An additional oxygen flowmeter was mounted in place of the cyclopropane flowmeter, and a universal vaporizer replaced the in-circuit ether vaporizer. A Model 885-Conversion superseded the Model 885 and was eventually replaced



**Fig. 7-1.** Most anesthetics given during the American Civil War, World War I, and World War II were administered by dripping ether onto a gauze-covered face mask.



**Fig. 7-2.** Field Anesthesia Machine (FAM) Model 885A with an oxygen analyzer. The circle-system machine has a vaporizer, carbon dioxide absorber, flowmeters, and an adult patient breathing circuit. Compressed medical gases are required. Photograph: Permission granted by Ohmeda, Inc, Madison, Wis.

by Model 885A. Hospitals mobilized for Operation Desert Shield (the build-up phase of the Persian Gulf War) were initially supplied with the FAM Model 885A and later with the Ohmeda Universal Portable Anesthesia Circuit (PAC) (Figures 7-2 and 7-3). Military anesthesia providers (especially those who were members of the reserves) realized that both anesthesia machines were not compatible with the techniques and standards of practice used in civilian and military hospitals in the United States. Most of the anesthesia providers in Operation Desert Storm (the fighting phase of the Persian Gulf War) considered the FAM and the PAC to be of historical importance only. Training with the machines was extremely limited, and the majority of anesthesia providers had been exposed only superficially to the principles of operation of a universal vaporizer. Many were hesitant to use the FAM and the PAC because they were unfamiliar with the machines and they were genuinely concerned about the standard of care and medicolability issues.

Military anesthesia providers require a small, lightweight, versatile, easily transportable anesthesia machine for use in a frontline aid station and in a rear, full-service field hospital. Historically, anesthesia providers in the United States have leaned heavily toward circle breathing systems; thus, this was a major determining factor in the development of anesthesia machines for the military. Two anesthesia machines are stocked by the Department of Defense's Deployable Medical Systems (DEPMEDS): the FAM and the PAC. The FAM is geared for use in field hospitals and in conflicts lasting longer than 2 weeks. The PAC fits inside a



**Fig. 7-3.** Ohmeda Portable Anesthesia Circuit (PAC). A draw-over vaporizer is the heart of this nonrebreathing lightweight anesthesia machine. Photograph: Permission granted by Ohmeda, Inc, Madison, Wis.

briefcase and is suitable for use in the battalion aid station and for fast-in and fast-out conflicts. Our discussion will focus on detailed descriptions of the FAM Model 885A and the PAC, and on concepts that might influence evolutionary changes for a new FAM.

### FIELD ANESTHESIA MACHINE MODEL 885A

Military anesthesia providers should familiarize themselves with the manufacturer's *Instruction and Service Manual With Illustrated Parts List*,<sup>1</sup> on which much of the following information is based. A distinctive carrying container, 13 in. wide x 20 in. long x 18 in. high, holds the entire FAM (Figure 7-4). All that is needed to put the machine into service is a cylinder of oxygen, carbon dioxide-absorbent granules, and a bottle of liquid anesthetic agent. The FAM and its container have a combined weight of 115 lb and can be lifted by grasping two handles on the lower case. During shipment, four glides are inserted into sprockets on the bottom of the container and these glides are replaced with four casters when the machine is assembled (Figure 7-5).

A pressure-release valve keeps dust from entering the container. The pressure-relief device must

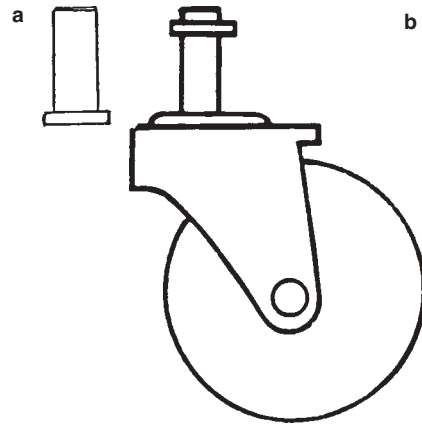
be pushed in to relieve the pressure inside the case before the lower and upper cases can be separated. Releasing four drawbolt fasteners separates the container into upper and lower cases (Figures 7-6 and 7-7).

#### Lower Case

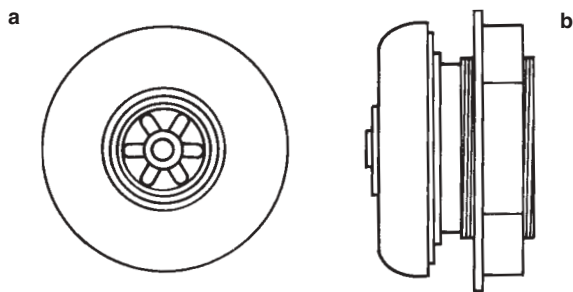
The lower case contains the anesthesia machine, accessories, and spare parts (Exhibit 7-1). As the absorber head is pulled upward, the support arms are held in vertical position by a spring-loaded snap bar at the base. A hinged thumb bolt is tightened into a slot on one support arm to keep the absorber head vertical (Figures 7-8 and 7-9). Between the two support arms are an open and a latched compartment (Figure 7-10). The open compartment has spring holders that secure adult- and child-sized



**Fig. 7-4.** Carrying case for the Field Anesthesia Machine (FAM) Model 885A. The upper and lower cases are held together by two drawbolts on each side of the case. Shipping glides have been replaced by four casters. Note one of the carrying handles on the end of the case.



**Fig. 7-5.** Four glides (a) are placed in sprockets on the bottom of the lower case for shipment and storage. Four casters (b), stored inside the bottom case, replace the glides when the Field Anesthesia Machine Model (FAM) 885A is in use. Redrawn with permission from Ohmeda, Inc, Madison, Wis.



**Fig. 7-6.** A pressure-release valve keeps dust and other materials from entering the case. Prior to opening the case, the center button (a, front view) is pushed to return pressure within the case to atmospheric conditions. A groove (b, side view) fits in a hole cut in the case wall and a flat bolt secures the device from the inside. Redrawn with permission from Ohmeda, Inc, Madison, Wis.



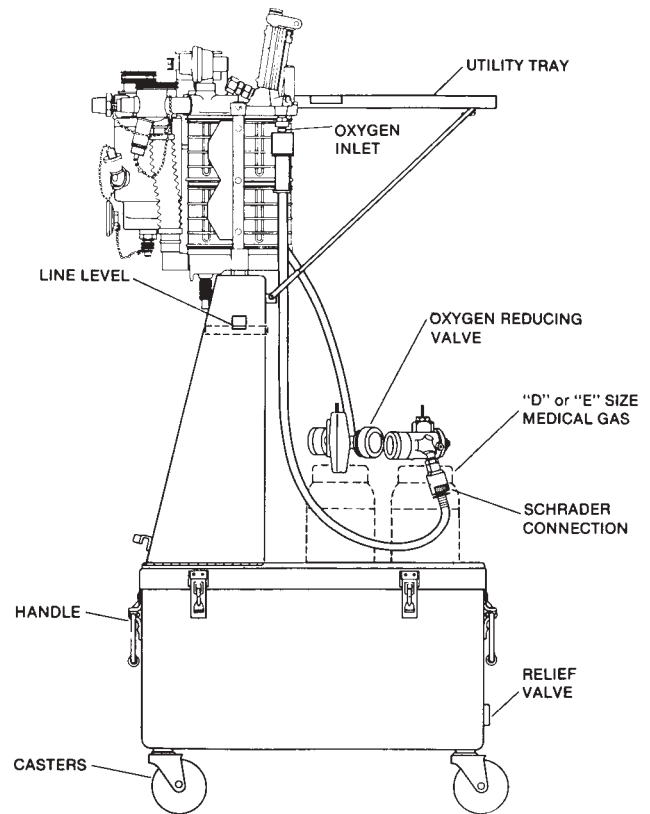
**Fig. 7-7.** Field Anesthesia Machine (FAM) Model 885A carrying case, opened. Bottom case (left) showing the FAM canister and rear of the flowmeter manifold. Upper case (right) with the medical gas hoses, a clipboard, and compressed gas regulators (one at each corner).

**EXHIBIT 7-1**

**ITEMS IN LOWER CASE, FIELD ANESTHESIA MACHINE MODEL 885A**

- 1<sup>5</sup>/<sub>16</sub>- and 1<sup>1</sup>/<sub>8</sub>-in. open-end wrench
- <sup>7</sup>/<sub>8</sub>- and <sup>3</sup>/<sub>4</sub>-in. open-end wrench
- Tee-valve wrench
- Flow calculator
- <sup>3</sup>/<sub>16</sub>-in. hex Allen wrench
- Y-inhaler
- Mask elbow
- Large and medium adult masks
- Child and infant masks
- Extra check valve disks
- Extra cylinder gaskets
- Extra funnel plug with chain
- Four wheels
- Large cylinder adapters for oxygen and nitrous oxide
- Protective closure devices for cylinder adapters
- Extra absorber gaskets
- Instrument tray
- Cylinder holder
- Gas evacuation tubing
- 19-mm connector
- Instrument tray with oxygen monitor case
- Oxygen sensor tee, probe, and cable
- Sight level

Adapted with permission from Ohmeda, Inc. *Instruction and Service Manual With Illustrated Parts List, Model 885A. Anesthesia Apparatus, Gas, Nitrous Oxide, Oxygen and Volatile Liquid Anesthetics, Portable 4-Cylinder Capacity.* Ohmeda, Madison, Wis: 1990: 14.

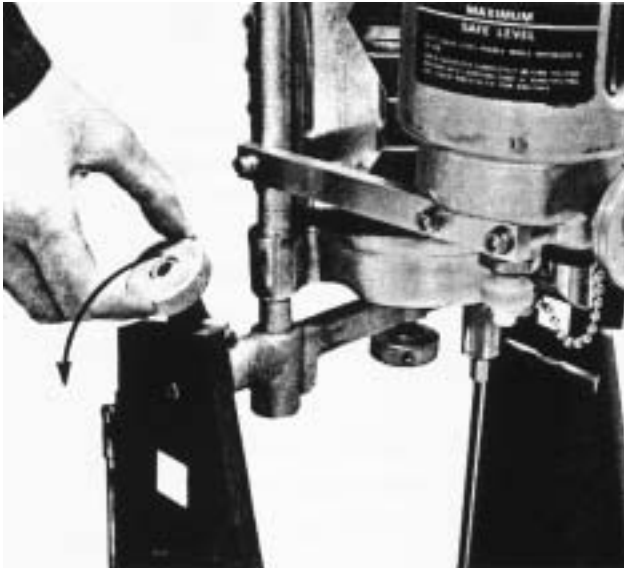


**Fig. 7-8.** Field Anesthesia Machine (FAM) Model 885A in the upright position. Side arms support the vaporizer and flowmeter manifold. One end of the utility tray is supported by a brace connected to the support arms. A line level on the inside of the support arm is used to level the machine prior to use. Casters have replaced the shipping glides. A gas-specific noninterchangeable male Schrader valve is attached to the female outlet of the pin-indexed reducing valve on the compressed oxygen cylinder. The opposite end of the oxygen hose has a female Schrader valve that is attached to the male oxygen inlet of the FAM. A carrying handle, two drawbolts, and the pressure-relief valve can be seen. A spring-latched bar (not seen) secures the bottom end of the support arms. Redrawn with permission from Ohmeda, Inc, Madison, Wis.

masks. Adjacent to the masks, in FAM models with an oxygen monitor, is an unsecured box containing the oxygen sensor cartridge. The latched compartment contains the elbow connector, the Y-connector for the breathing circuit, a box with three vials of extra parts, and the tee-valve wrench (which is used to turn the E-cylinder to the ON position). Replacement parts in the three vials include vaporizer replacement parts, cylinder yoke gaskets, and disks for the inhalation and exhalation check valves. If the FAM has an oxygen monitor,

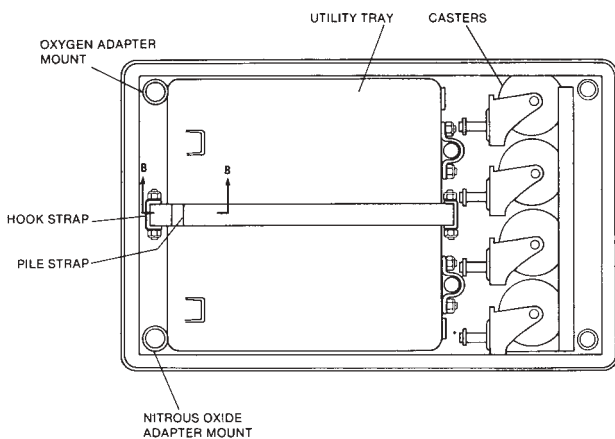
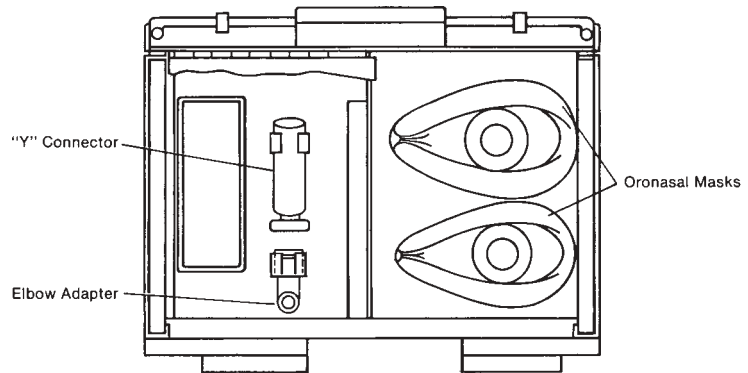
the cable assembly and sensor tee will be stored in the box.

Corrugated scavenger hoses are stored inside the absorber chamber. Lifting the absorber head reveals the utility tray, which is held in place by a hook-and-loop strap and four casters snapped into spring holders (Figure 7-11). The front end of the tray has two round brackets that slide onto two mounting studs behind the flowmeter manifold (Figure 7-12). A tray brace is permanently attached to the top of the support arms and fits snugly



**Fig. 7-9.** Field Anesthesia Machine (FAM) Model 885A. A hinged thumb bolt secures the absorber head in the vertical position. Photograph: Printed with permission from Ohmeda, Inc, Madison, Wis.

**Fig. 7-10.** Field Anesthesia Machine (FAM) Model 885A. The space between the support arms contains two compartments. An open compartment has two posts holding oronasal masks. A lid (shown removed) for the closed compartment protects the Y breathing-circuit connector, the elbow adapter, spare parts containers, and the tee valve wrench for E-cylinders. Models with an oxygen sensor have the sensor cartridge stored next to the masks and the sensing cable and sensing tee inside the closed compartment. Redrawn with permission from Ohmeda, Inc, Madison, Wis.

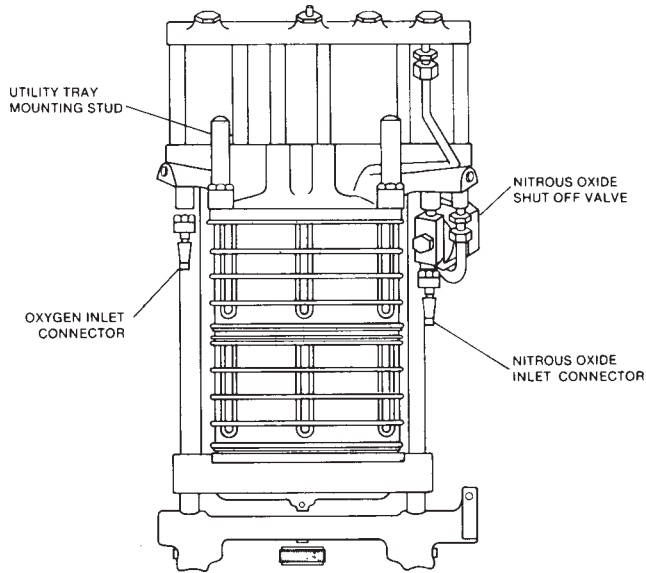


**Fig. 7-11.** Field Anesthesia Machine (FAM) Model 885A. After the absorber head is in the vertical position, the utility tray, casters, and mounts for the oxygen and nitrous oxide H-cylinder adapter can be seen. Spring-loaded clamps in the end of the case secure either the casters or glides. A strap holds the utility tray in place. Redrawn with permission from Ohmeda, Inc, Madison, Wis.

against the edge of the support arms when not in use. The tray brace slides into two brackets on the underside of the utility tray to support the opposite end of the tray (see Figure 7-8).

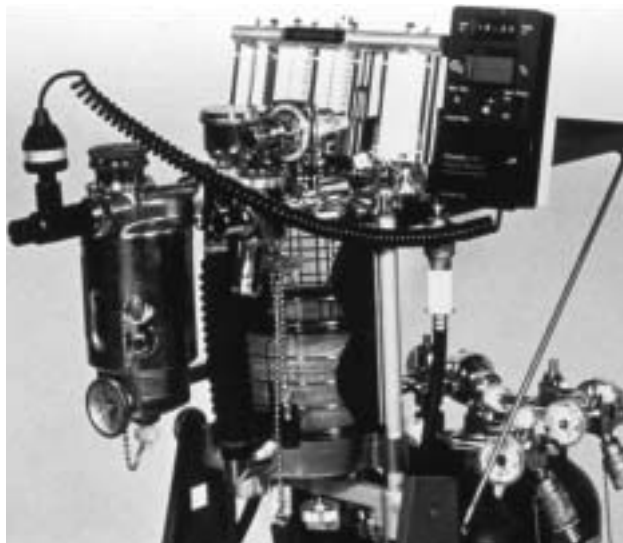
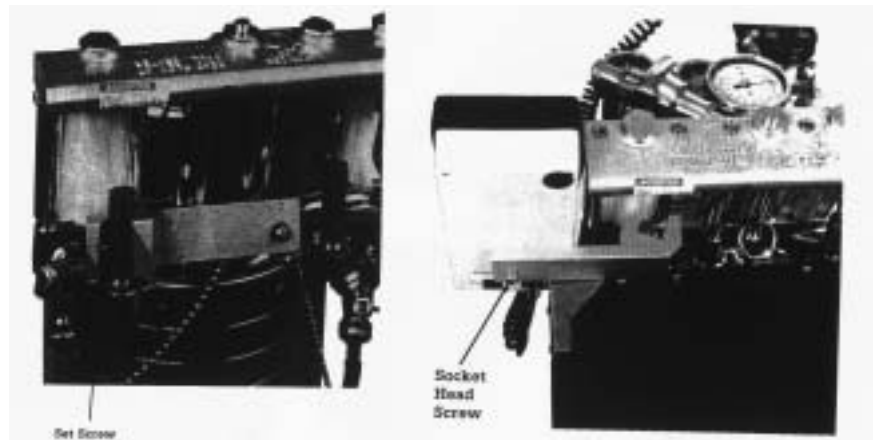
The mounting bracket for the oxygen monitor is attached by a set screw to the utility mounting stud

on the side of the metabolic oxygen flowmeter (Figure 7-13). During assembly, the set screw is loosened and the bracket is moved parallel to the flowmeter manifold, and the oxygen monitor is then mounted to the bracket. The oxygen sensor probe is inserted in the sensor tee placed between

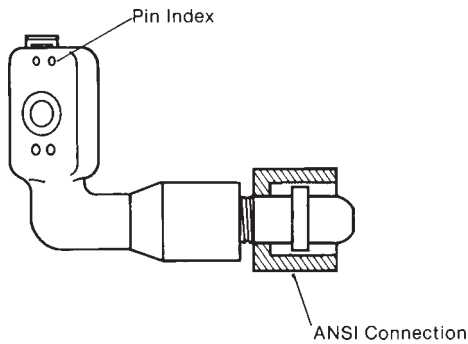


**Fig. 7-12.** Field Anesthesia Machine (FAM) Model 885A. Rear view of the absorber head. Two mounting studs hold one end of the utility tray. Inlet male noninterchangeable Schrader connectors for oxygen and nitrous oxide are shown. The nitrous oxide pressure-sensor shutoff valve blocks the flow of nitrous oxide to the flowmeter when the pressure of oxygen in the pipeline is less than 20 psig. Reprinted with permission from Ohmeda, Inc, Madison, Wis.

**Fig. 7-13.** Field Anesthesia Machine (FAM) Model 885A. The oxygen mounting bracket is attached to one of the utility mounting studs during shipment (left). Releasing the set screw allows the bracket to be moved approximately 180°. The oxygen monitor is mounted on the bolt pictured at the end of the bracket (right). Redrawn with permission from Ohmeda, Inc, Madison, Wis.



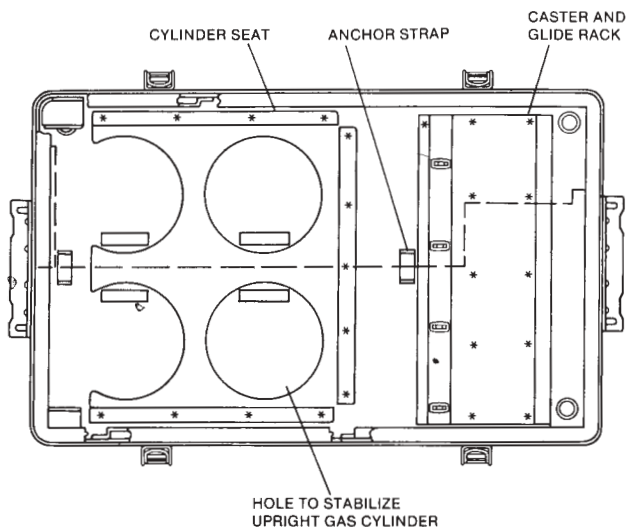
**Fig. 7-14.** Field Anesthesia Machine (FAM) Model 885A. The oxygen monitor is mounted to the bracket of the absorber head. A sensor cable connects the oxygen sensor in the sensor tee of the fresh-gas outlet of the breathing circuit to the monitor. The inspiratory limb of the breathing circuit will be attached to the open end of the sensor tee. Photograph: Printed with permission from Ohmeda, Inc, Madison, Wis.



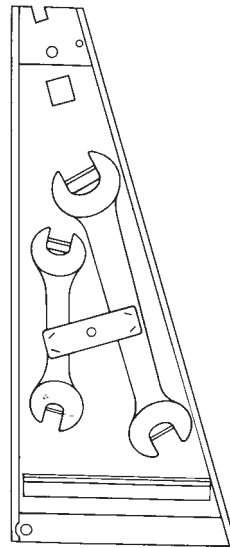
**Fig. 7-15.** Field Anesthesia Machine (FAM) Model 885A, large-cylinder adapter. An American National Standards Institute (ANSI) nut-and-gland medical gas-coded thread attaches to a matching threaded cylinder outlet. The opposite end of the adapter has a pin-index safety system (PISS) that is gas-specific (a PISS regulator is attached to the PISS fitting). Redrawn with permission from Ohmeda, Inc, Madison, Wis.

the common gas outlet and the inspiratory limb of the patient breathing circuit (Figure 7-14).

Large cylinder connectors for oxygen and nitrous oxide are stored on threaded mounts (see Figure 7-11) adjacent to the end of the utility tray. These connectors attach to cylinders, which do not have the pin index safety system (PISS) holes drilled in the cylinder valve. An American National



**Fig. 7-16.** Field Anesthesia Machine (FAM) Model 885A. After the utility tray is removed, the four-holed cylinder holder can be taken out and fitted to the cylinder seat on top of the lower case to help secure the E-cylinders in the upright position. The weight of the cylinders contributes to the stability of the FAM. Redrawn with permission from Ohmeda, Inc, Madison, Wis.



**Fig. 7-17.** Field Anesthesia Machine (FAM) Model 885A. Two wrenches for connecting cylinder adapters are mounted on the inside of one support arm. Redrawn with permission from Ohmeda, Inc, Madison, Wis.

Standards Institute (ANSI) nut-and-gland medical-gas-coded thread of the connector attaches to the threaded cylinder outlet; the other end of the connector has the appropriate PISS for the gas-specific cylinder regulator gauge (Figure 7-15). Beneath the utility tray is a four-holed cylinder holder that mounts on the top of the lower case and keeps the E-cylinders in place during use (Figure 7-16). Mounted on one side of the lower case wall is the flow calculator, which is used to determine anesthetic concentrations delivered by the universal vaporizer.

On the inside of one support arm are extra absorber gaskets and a small sight level for leveling the machine during assembly (see Figure 7-8). On the inside of the other support arm are two open-end wrenches, which are used for connecting connectors to cylinders, and for other purposes (Figure 7-17).

### Upper Case

Additional equipment and accessories for assembling the completed anesthesia machine are contained in the upper case (Exhibit 7-2). Figure 7-18 shows the fastener holding the clipboard in place. A compartment secured by a fastener is on each end of the upper case. When the clipboard is removed and the compartments are opened, the rebreathing bags, head harness, oxygen and nitrous oxide PISS regulators, long and short gas-supply hoses, corrugated breathing tubes, and equipment for a pediatric nonrebreathing system are revealed (Figure 7-19).



**EXHIBIT 7-2**

**ITEMS IN UPPER CASE, FIELD ANESTHESIA MACHINE MODEL 885A**

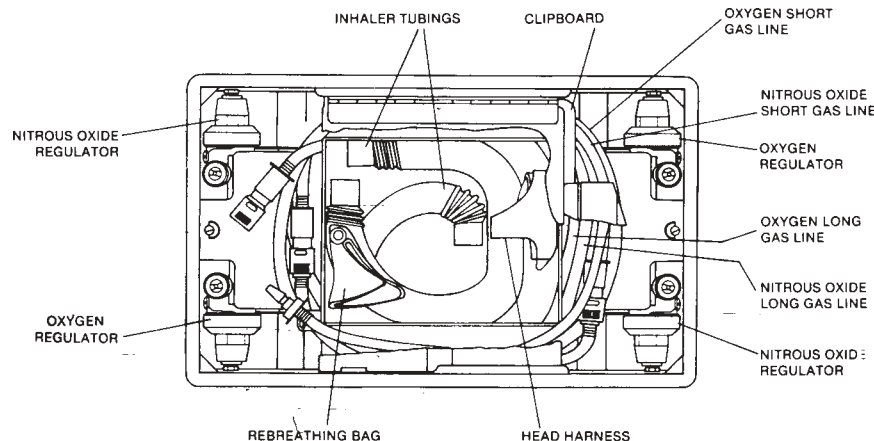
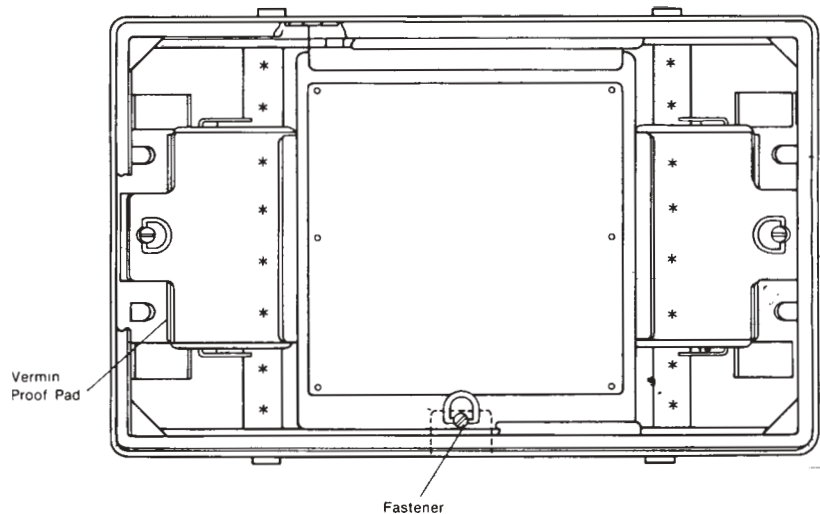
- Long and short gas-supply hoses for oxygen and nitrous oxide
- Regulator assemblies for oxygen and nitrous oxide
- Head strap
- Long and short corrugated breathing tubes
- Clipboard
- Pediatric supply hose
- 1-L Breathing bag with scavenging valve
- 3-L Breathing bag

Adapted with permission from Ohmeda, Inc. *Instruction and Service Manual With Illustrated Parts List, Model 885A. Anesthesia Apparatus, Gas, Nitrous Oxide, Oxygen and Volatile Liquid Anesthetics, Portable 4-Cylinder Capacity.* Ohmeda, Madison, Wis: 1990: 14.

**Attaching the Medical Gas Supply**

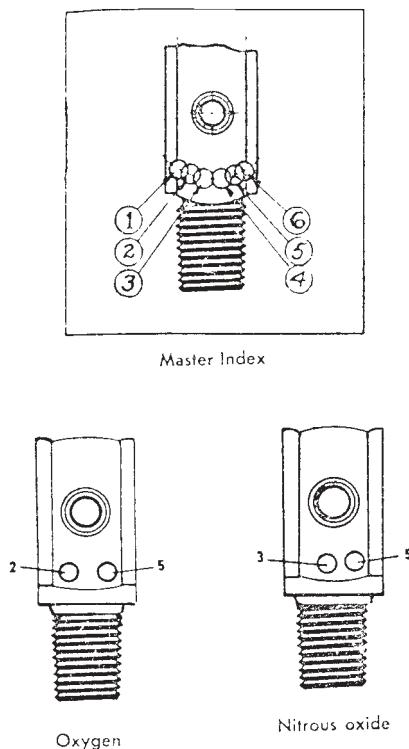
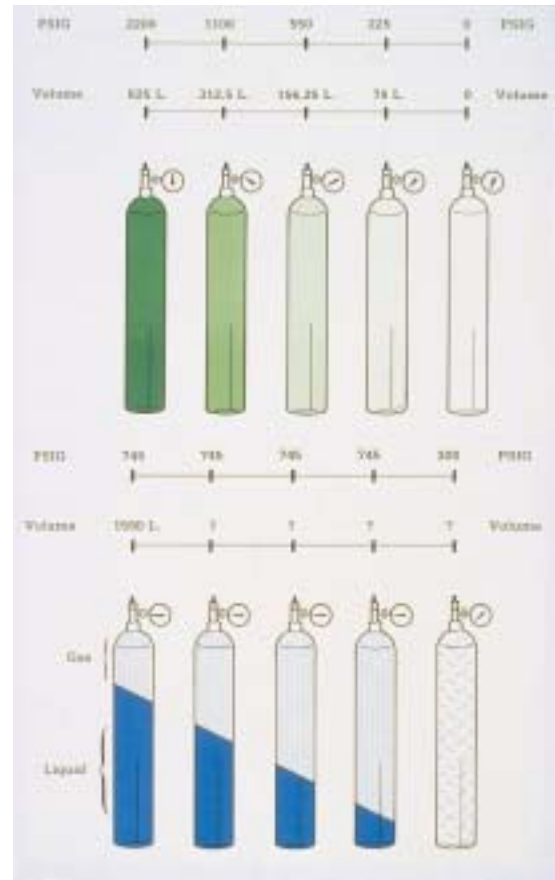
Cylinders containing oxygen and nitrous oxide are connected to the anesthesia machine by using the PISS regulator for E-cylinders or the large-cylinder PISS adapters. E- or D-cylinders will fit inside the four-holed holder in the lower case (see Figures 7-8 and 7-16). It is important to briefly review the differences in physical characteristics between the storage and the delivery of oxygen and nitrous oxide. E-cylinders (internal volume 4.8 L) at 21.1°C (70°F) contain either 660 L of compressed oxygen at a pressure of 1,900 psig or 2.92 kg of liquid nitrous oxide (which evaporates to provide 1,590 L) at a pressure of 750 psig.<sup>2</sup> Oxygen boils at -183.0°C at 1 atm and has a *critical temperature* (ie, the temperature above which a substance cannot be liquefied regardless of the pressure applied) of -118.6°C.<sup>3</sup> Oxygen can only be stored as a gas at room temperature, and the amount of oxygen in the cylinder is proportional to the cylinder pressure (Figure 7-20). Nitrous oxide at room temperature is below its critical temperature and is stored as a liquid under pressure

**Fig. 7-18.** Field Anesthesia Machine (FAM) Model 885A. Upper case. A fastener is holding the clipboard in place. Fastened compartments are shown at opposite ends of the case. Redrawn with permission from Ohmeda, Inc, Madison, Wis.



**Fig. 7-19.** Field Anesthesia Machine (FAM) Model 885A. Breathing tubes, a head harness, rebreathing bags, a pediatric nonrebreathing circuit, and gas hoses are stored beneath the clipboard in the upper case. A pin index safety system (PISS) gas regulator is secured at each corner of the case. Redrawn with permission from Ohmeda, Inc, Madison, Wis.

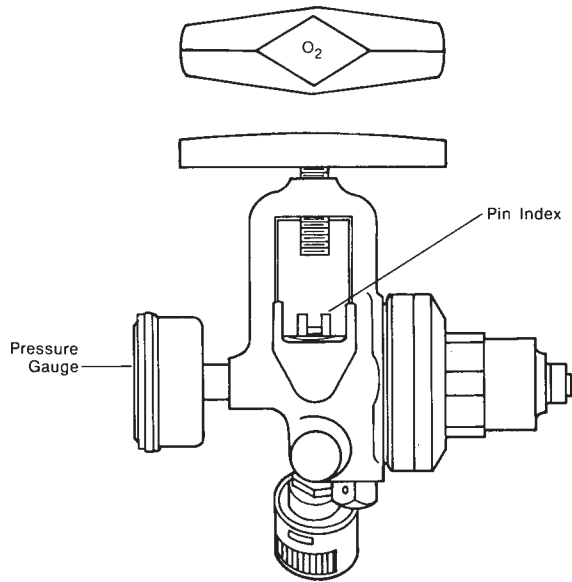
**Fig. 7-20.** Oxygen and nitrous oxide compressed-gas cylinders. Oxygen (green) is stored as a compressed gas because it is above its critical temperature at room temperature. The amount of oxygen in the cylinder is proportional to the cylinder pressure. Nitrous oxide (blue) is stored as a liquid under pressure. As the tank empties, the amount of nitrous oxide in the cylinder is *not* proportional to the pressure in the cylinder. When the last drop of liquid nitrous oxide is evaporated, the cylinder contains *only* gas, and *then* the amount of nitrous oxide in the cylinder is proportional to the amount of gaseous nitrous oxide. Photograph: Printed with permission granted by Medical Systems Division, Ohmeda, Inc, Madison, Wis.



**Fig. 7-21.** The pin index safety system (PISS), which is designed for medical gases compressed in cylinders. Each medical gas is assigned two holes of the six-holed main index (upper figure). Oxygen is assigned positions 2 and 5 and nitrous oxide positions 3 and 5. Above the two holes is the cylinder-gas outlet.

in the cylinder. The content of the nitrous oxide cylinder is *not* proportional to the cylinder pressure *until* the liquid nitrous oxide has completely evaporated.

An E-cylinder valve in the United States must comply with the PISS. Three holes are drilled in the cylinder valve: one is the gas outlet and the other two are limited-depth holes that are positioned to correspond with the assigned PISS for oxygen (numbers 2 and 5) or nitrous oxide (numbers 3 and 5) (Figure 7-21). Both FAM oxygen and nitrous oxide regulators have two pins that mate with the paired holes in the cylinder valve (Figure 7-22). The oxygen regulator is marked with the chemical symbol  $O_2$  and is painted white (the international color code for oxygen) on the pressure gauge dial face and the tee-securement handle. The nitrous oxide regulator is marked with the chemical symbol  $N_2O$  and painted blue (the international color code for nitrous oxide) on the pressure gauge dial face and the tee-securement handle. After a regulator is attached to either an E-cylinder valve or a large-cylinder PISS connector, a male Schrader noninterchangeable connector (Figure 7-23) on the



**Fig. 7-22.** Oxygen regulator. Two pins are positioned to fit the 2,5 pin index safety system (PISS) of the oxygen cylinder valve. The handle is painted white (international color assigned to oxygen) and is labeled with the chemical symbol for oxygen. A pressure gauge reflects the cylinder pressure in psig and kg/cm<sup>2</sup>, is painted white, and labeled O<sub>2</sub>. A male Schrader noninterchangeable connector can be seen at the bottom of the regulator. Redrawn with permission from Ohmeda, Inc, Madison, Wis.

**Fig. 7-23.** Schrader noninterchangeable connectors at the ends of the gas hoses. Each medical gas has a specific connector assigned to avoid cross-connection of gases. One end of the gas hose has a male connector (left) that fits the gas-specific female connector (right) on the pin index safety system (PISS) regulator, and the other end has a female connector that fits the male inlet connection on the Field Anesthesia Machine (FAM) Model 885A. Schrader adapters allow rapid connections and disconnections without the use of special tools. Photograph: Printed with permission of Ohmeda, Inc, Madison, Wis.



medical gas-supply hose is inserted into the gas-specific female Schrader connector on the regulator. Gas-supply hoses come in two lengths, 114 and 40 in. A color-coded identification disk is found on each end of the supply hose. The female Schrader connection on the opposite end of the medical gas-supply hose is then connected to the male Schrader inlet connector on the control head. Figure 7-8 shows the connection of an E-cylinder containing oxygen to the FAM.

Cylinders larger than E-cylinders are sometimes supplied to combat hospitals to improve the efficiency of the medical gas supply (Figures 7-24 and 7-25). A large cylinder connector (see Figure 7-15), which is nut-and-gland coded for either oxygen or nitrous oxide, is attached to the threaded cylinder outlet, and a PISS oxygen or nitrous oxide regulator is attached to the PISS-connector outlet.

When an oxygen-powered ventilator is required, it is necessary to use either (a) the second oxygen regulator, attached to an E-cylinder or large-cylin-

der connector, or (b) an oxygen regulator equipped with two male Schrader connectors (Figure 7-26).

### Pipeline Circuits

Gases from the oxygen and nitrous oxide cylinders enter the FAM through the two male Schrader noninterchangeable inlets on the rear of the control head (see Figure 7-12). Before the gases enter the FAM circuit, the regulator has reduced the pressure to approximately 40 psig. Nitrous oxide must flow through the pressure-sensor shutoff valve before it can enter the nitrous oxide flowmeter (see Figure 7-12 and Figures 7-27 and 7-28). The pressure-sensor shutoff valve will block the flow of nitrous oxide to the flowmeter if the oxygen pressure on its diaphragm is less than 20 psig.

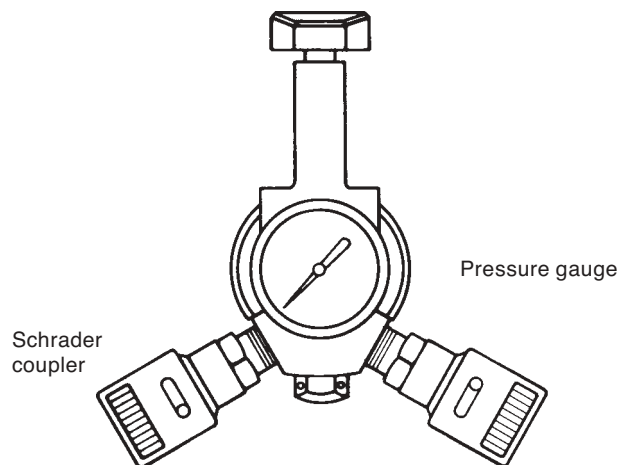
Oxygen is distributed to four areas after it enters the FAM: (1) the metabolic oxygen flowmeter control valve, (2) the diaphragm of the nitrous oxide pressure-sensor shutoff valve, (3) the oxygen

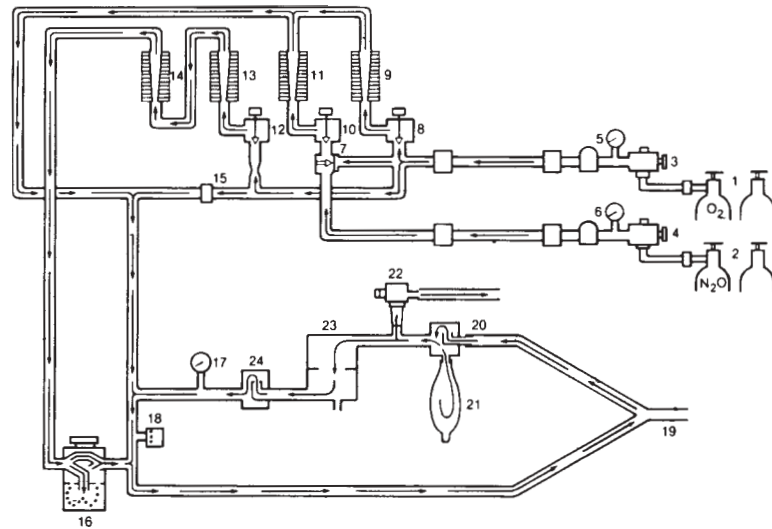
**Fig. 7-24.** Field Anesthesia Machine (FAM) Model 885A at the 93rd Evacuation Hospital, Rafha, Saudi Arabia, during the Persian Gulf War. Two operations are under way in the same operating room. The FAM can be seen on the right. Photograph: Courtesy of Captain DJ Rutkowski, CRNA, US Army Nurse Corps.



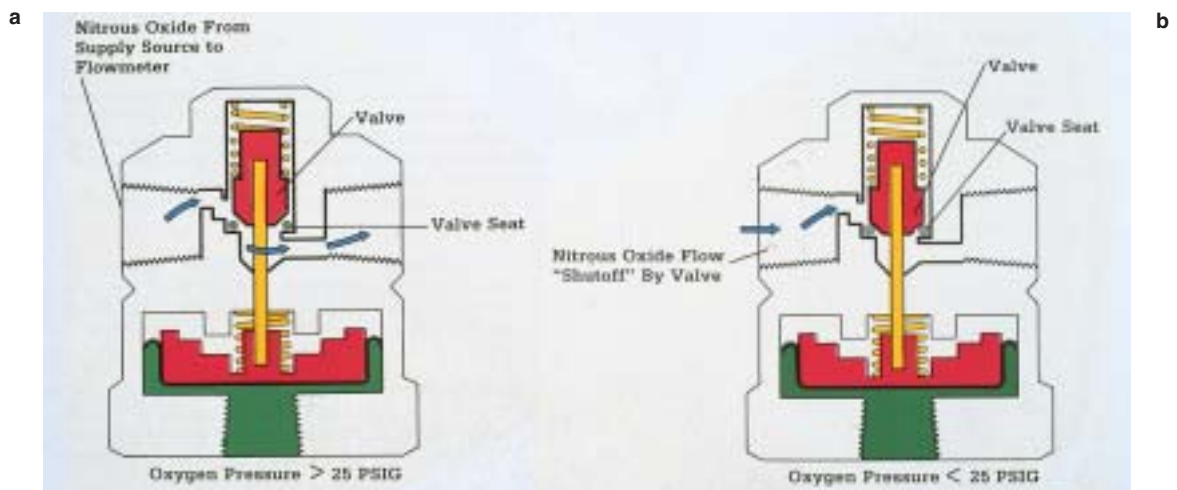
**Fig. 7-25.** Anesthesia equipment at the 12th Evacuation Hospital in Saudi Arabia during the Persian Gulf War. Patient monitors, a Field Anesthesia Machine (FAM) Model 885A with an oxygen monitor, a ventilator, and a blood warmer are shown. The rebreathing bag is attached to a switch-over valve that simplifies the adaptation of the ventilator to the breathing circuit. Against the wall (left) are two H-cylinders of compressed oxygen. These cylinders are painted two colors: green (US designation for oxygen) and white (international color assigned to oxygen), and are stamped OXYGEN in white letters on the green section of the cylinder. One oxygen H-cylinder is being used to power the ventilator, and the adapter and pin index safety system (PISS) regulator provided with the FAM are not being used. Nonstandard breathing tubes are connected to the FAM. Photograph: Courtesy of Captain DJ Rutkowski, CRNA, US Army Nurse Corps.

**Fig. 7-26.** A pin index safety system (PISS) oxygen regulator fitted with two Schrader couplers. One supplies oxygen to the Field Anesthesia Machine (FAM) Model 885A, and the other is a power outlet for the ventilator. Redrawn with permission from Ohmeda, Inc, Madison, Wis.





**Fig. 7-27.** Field Anesthesia Machine (FAM) Model 885A pipeline schematic for oxygen and nitrous oxide. Oxygen from the compressed medical oxygen cylinder (1) is reduced (3) to a pressure of 40 psig (5) before entering the FAM. Oxygen is distributed to metabolic oxygen flowmeter control valve (8), diaphragm of the nitrous oxide pressure sensor shutoff valve (7), oxygen flush valve (15), and the oxygen-for-vaporizer flowmeter control valve (12). Nitrous oxide in cylinders (2) is reduced (4) to 40 psig (6) before it enters the FAM. Nitrous oxide passes through the nitrous oxide pressure-sensor shutoff valve (7) to the nitrous oxide flowmeter control valve (10). Metabolic oxygen (9) and nitrous oxide (11) mix in a common pipeline and then combine with the oxygen-for-vaporizer (13, 14) and anesthetic agent emitting from the vaporizer (16). Mixed gases are carried by the inspiration limb of the breathing circuit to the Y piece (19) and then to the patient. Exhaled gases enter the expiratory limb and flow through the exhalation check valve (20), some of the gases go into the rebreathing bag (21), and some exit through the adjustable pressure-limiting valve (22), if it is open, into the scavenging system; the remaining gases pass through the carbon dioxide absorber (23), through the inspiration check valve (24), and begin the cycle again. A pressure gauge (17) monitors breathing-circuit pressure. An emergency nonadjustable pressure-relief valve (18) releases gases into the atmosphere when the circuit pressure exceeds 60 to 80 mmHg. Photograph: Printed with permission from Ohmeda, Inc, Madison, Wis.



**Fig. 7-28.** This diagram shows how the nitrous oxide pressure-sensor shutoff valve works. (a) When the oxygen line pressure exceeds 25 psig, a large diaphragm counteracts the force applied by a valve-return spring on the valve. In this position, nitrous oxide flows through the shutoff valve. (b) Oxygen pressure drops below 25 psig and the valve-return spring forces the valve to seat, closing the shutoff orifice. Nitrous oxide still flows to the pressure-sensor shutoff valve but cannot flow through the valve to the nitrous oxide flowmeter. Photograph: Printed with permission granted by Medical Systems Division, Ohmeda, Inc, Madison, Wis.



**Fig. 7-29.** Top of the flowmeter manifold, showing the assigned numbers imprinted for each medical gas. The numbers above the bolt holding the flow tube in place must match the number on the bottom of the flow tube. From the left, number 2 is for nitrous oxide, 4 is for low-flow oxygen-for-vaporizer, 5 is for high-flow oxygen-for-vaporizer, and 1 is for metabolic oxygen. Switching flow tubes can be disastrous because the output of the flowmeter is determined by the specific viscosity and density of the medical gas flowing through the flow tube.

flush valve, and (4) the oxygen-for-vaporizer flowmeter.

### Flowmeters

Flowmeters are provided for metabolic oxygen, oxygen for the vaporizer, and nitrous oxide. The range for the flowmeters is, for metabolic oxygen, 200 mL/min to 7 L/min; for low-flow oxygen for the vaporizer, 20 to 180 mL/min; for high-flow oxygen for the vaporizer, 100 mL/min to 1 L/min; and for nitrous oxide, 200 mL/min to 8 L/min. Accuracy for all flowmeters is  $\pm 20\%$  up to flows of 1,000 mL/min; above flows of 1,000 mL/min, the accuracy is  $\pm 10\%$  (eg, at a setting of 5 L/min, the output would be 4.5–5.5 L/min). Each flowmeter tube, float, and scale are a matched set and must be replaced as a unit. Each flow tube is gas-specific, and a numbering system on the flowmeter manifold and each matching flow tube enhances the correct placement of the flow tubes if they are removed for maintenance or replacement. Numbers on the top of the flowmeter manifold are placed above the bolt that holds the flowmeter in place (Figure 7-29). Metabolic oxygen is number 1; oxygen-for-vaporizer, high flow, is 5; oxygen-for-vaporizer, low flow, is 4; and nitrous oxide is 2. The corresponding number is printed on the bottom of the flow tube. Switching flow tubes can be disastrous. One of the two documented deaths attributed to the FAM occurred when someone switched the nitrous oxide flow tube with the high-flow oxygen-for-vaporizer flow tube.<sup>4</sup> This switch resulted in a delivery of 6.2% isoflurane instead of the expected 1.5% setting, and the overdosing and eventual death of the patient.

Flowmeter scales and control knobs are color coded: metabolic oxygen is white, oxygen-for-vaporizer



**Fig. 7-30.** The metabolic oxygen flowmeter control knob is fluted, labeled O<sub>2</sub>, painted white (international color assigned to oxygen), and is positioned on the far right. The flow-tube scale is labeled O<sub>2</sub>, ranges from 0.2 to 7 L/min, is also white, and is protected by a plastic shield. The adjustable pressure-limiting (pop-off) valve can be seen, with the proximal end of the scavenger hose attached.

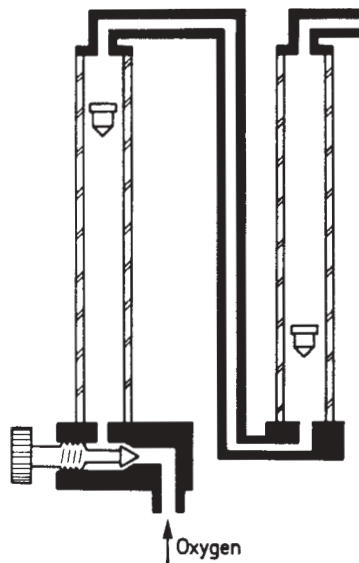


**Fig. 7-31.** Nitrous oxide and oxygen-for-vaporizer flowmeter control knobs and flow tubes. Nitrous oxide is labeled N<sub>2</sub>O and is painted blue (international and US color assigned to nitrous oxide). The nitrous oxide-flow-tube scale is labeled N<sub>2</sub>O, ranges from 0.2 to 8 L/min, is painted blue, and is protected by a plastic shield. The oxygen-for-vaporizer control knob is painted yellow (manufacturer's choice), and is labeled O<sub>2</sub> FOR VAPORIZER. The single oxygen-for-vaporizer flowmeter control knob meters both low- and high-flow oxygen. The flow-tube scales are labeled O<sub>2</sub>, painted yellow, and protected by a plastic shield; the low-flow tube ranges from 20 to 180 cc/min, and the high-flow tube ranges from 100 to 1,000 cc/min. The nitrous oxide pressure-sensor shutoff valve can be seen below the nitrous oxide flowmeter housing.

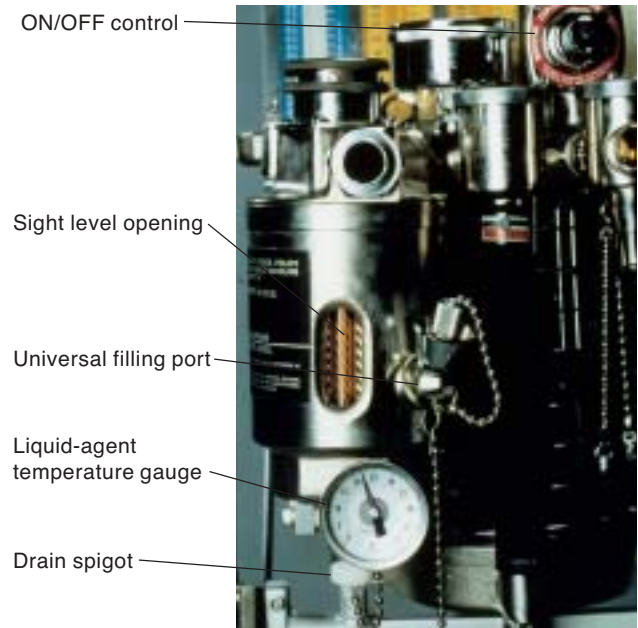
porizer is yellow, and nitrous oxide is blue (Figures 7-30 and 7-31). Flowmeters and scales are protected by a transparent plastic shield. Metabolic oxygen and nitrous oxide flow into a common pipeline circuit at the top of the flowmeter manifold. The high and low flowmeters for oxygen-for-vaporizer are controlled by a single knob. The flow first enters the bottom of the low-flow tube, exits the top and enters the bottom of the high-flow tube, and finally exits the top of the high-flow tube to enter the common gas pipeline (Figure 7-32). Oxygen-for-vaporizer bubbles through the anesthetic liquid and carries anesthetic vapor into the common gas outlet *if* the vaporizer control dial is in the ON position; otherwise, the oxygen bypasses the vaporizer and enters directly into the common gas outlet. The metabolic oxygen flowmeter control knob is fluted (see Figure 7-30) to enhance identification.

### Vaporizer

The FAM 250 mL vaporizer will deliver accurate, metered concentrations of isoflurane, halothane,



**Fig. 7-32.** The single-control flowmeter knob controls flow through the low- and high-flow tubes. Oxygen flow rate is metered by the position of the control knob in the cone-shaped orifice. Oxygen passes into the low-flow tube, causing the float to rise. Increasing the flow of oxygen causes the float in the low-flow tube to stay at the top, as oxygen passes into the high-flow tube and begins to lift the float in the high-flow tube. All oxygen eventually exits from the top of the high-flow tube on its way to the vaporizer. Photograph: Reprinted with permission from Schreiber P. *Safety Guidelines for Anesthesia Systems*. Telford, Pa: North American Dräger; 1985: 17.



**Fig. 7-33.** Field Anesthesia Machine (FAM) Model 885A vaporizer, showing the ON/OFF control, the sight level opening, the universal filling port, the liquid-agent temperature gauge, the drain spigot, and the common gas-outlet port.

enflurane, ether, and chloroform (Figure 7-33). Desflurane cannot be used in the vaporizer because of its unique vapor pressure. The vaporizer is a brass container filled with a liquid anesthetic. Brass is a reasonably priced metal with acceptable thermal conductivity and specific heat characteristics. A dedicated oxygen-for-vaporizer flowmeter bubbles oxygen through the liquid in the vaporizer when the ON/OFF control is in the ON position. Agent output is determined by the same principles that govern the copper kettle (Figure 7-34). Each bubble of oxygen is saturated with the vapor of the liquid anesthetic. The large surface area of the oxygen bubble allows ample time for the liquid anesthetic agent to evaporate inside the bubble and to fully saturate the oxygen flowing through the vaporizer. Eventually, the oxygen entering the liquid anesthetic plus the anesthetic vapor exit the top of the vaporizer and are diluted by the metabolic oxygen and nitrous oxide in the common gas outlet. At least 50 mL of anesthetic liquid must be in the vaporizer for the anesthesia provider to be certain that the desired vapor concentration is delivered.

Many formulas can be used to calculate the final output of anesthetic agent concentration in the inspiratory limb of the breathing circuit. Approxi-

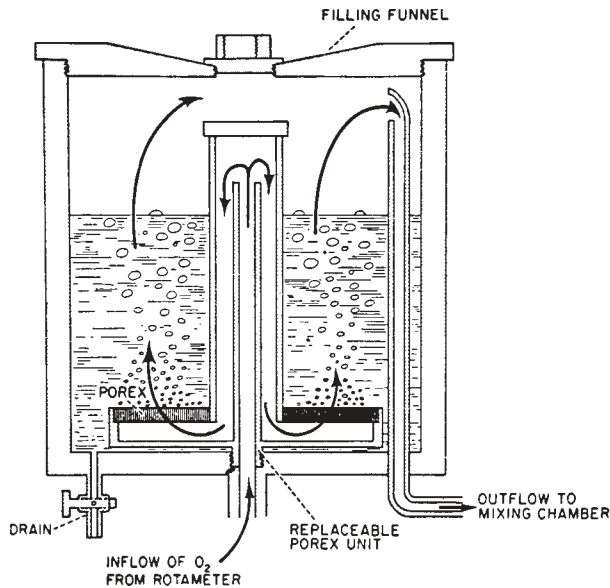


Fig. 7-34. Copper kettle bubble-through vaporizer. Output is determined by the temperature of the liquid anesthetic, the vapor pressure of the liquid anesthetic, the rate of oxygen bubbling through the liquid, and the barometric pressure. The Field Anesthesia Machine (FAM) Model 885A is a bubble-through vaporizer that can accept the majority of inhalational anesthetic agents. Photograph: Reprinted with permission from Morris LE. A new vaporizer for liquid anesthetic agents. *Anesthesiology*. 1952;13:587.

mate calculations of output are accurate enough for clinical application, of which the following is one method<sup>5</sup>:

- Derivation:

$$\% = \frac{VF \text{ [mL/min]} \cdot [P_a / \{P_b - P_a\}] \cdot 100}{TF \text{ [L/min]} \cdot 1,000}$$

where % represents the percentage concentration of anesthetic in the inspiratory limb of the breathing circuit, VF represents the flow of oxygen through the vaporizer (in mL/min), TF represents the total gas flow (in L/min),  $P_a$  represents the vapor pressure of volatile agent (in mm Hg), and  $P_b$  represents barometric pressure (in mm Hg).

- Simplification:

- Vapor pressure of halothane is 243 mm Hg at 20°C and 760 mm Hg barometric pressure
- Therefore, by substitution:

$$\% = \frac{VF \cdot [243 / \{760 - 243\}] \cdot 100}{TF \cdot 1,000}$$

$$\% = \frac{0.47 VF}{10 TF} \quad \text{or} \quad \% \sim \frac{0.5 VF}{10 TF}$$

- Therefore,  $VF \sim TF \cdot 20 \cdot \%$ .
- Practical applications:
  1. An induction concentration of 3% halothane is desired.  
 Temperature 20°C, barometric pressure 760 mm Hg, fresh-gas flow of 5 L/min:  
 $VF \sim 5 \cdot 20 \cdot 3\%$   
 $VF = 300 \text{ mL/min}$ 
    - Set vaporizer control to the ON position.
    - Set metabolic oxygen and nitrous oxide flowmeters to deliver a combined flow of 5 L/min.
    - Set oxygen-for-vaporizer flowmeter at 300 mL/min.
  2. To obtain a maintenance of 1% halothane in the inspiratory limb of the breathing circuit at 20°C, barometric pressure of 760 mm Hg, and a fresh-gas flow of 2 L/min:  
 $VF \sim 2 \cdot 20 \cdot 1\%$   
 $VF = 40 \text{ mL/min}$ 
    - Leave vaporizer control at ON position.
    - Set metabolic oxygen and nitrous oxide flowmeters to give a combined flow of 2 L/min.
    - Set oxygen-for-vaporizer flowmeter at 40 mL/min.

To simplify the calculation of vaporizer output concentration, a Verni-Trol (manufactured by Ohmeda, Inc., Madison, Wis.) anesthetic vaporizer-flow calculator is included in the lower case of the FAM (Figure 7-35). This calculator is a miniature slide rule designed for one task: to determine the final concentration of anesthetic agent in the inspiratory limb of the breathing circuit. The anesthesia provider first finds the desired concentration of the anesthetic agent vapor on the outermost scale of the calculator (labeled % CONCENTRATION). Then the desired total flow rate on the TOTAL FLOW scale is aligned with the anesthetic agent concentration value. Set the hairline LIQUID TEMPERATURE scale value for the agent in the vaporizer to correspond to the temperature of the liquid in the vaporizer. Finally, read the required oxygen-for-vaporizer flowmeter setting where the hairline crosses the Flow Thru Verni-Trol scale. These steps are illustrated in the following example:



- The desired total flow rate is 5 L/min.
  - Desired concentration of *halothane* is 1%.
  - Vaporizer thermometer reading is 25°C.
- Find 1% on the CONCENTRATION scale.
  - Align 5 L/min value on the TOTAL FLOW scale with the 1% value.
  - Find 25°C on the halothane LIQUID TEMPERATURE scale and set the hairline.
  - The hairline will cross Flow Thru Verni-Trol scale at 100 mL/min value.
- Set metabolic oxygen and nitrous oxide flowmeters to give a combined 5 L/min flow.
  - Set vaporizer control on vaporizer to the ON position.
  - Set oxygen-for-vaporizer flowmeter at 100 mL/min.

Temperature has a profound effect on vapor pressure and must always be factored in when using the vaporizer in field conditions. Total flow rates have major effects on concentration. During induction, high flow rates are used; when switching to lower flows for maintenance, the anesthesia provider must recalculate the flow required through the vaporizer for maintenance levels of anesthetic.



Most anesthesia providers are not familiar with the calculations or the Verni-Trol calculator because single-agent temperature- and pressure-compensated vaporizers have replaced Verni-Trol-type vaporizers. During the Persian Gulf War, many anesthesia providers believed that the FAM Model 885 vaporizer was outmoded, dangerous, and should have been replaced immediately. Not many took the time to learn the technology of a past era, and only a few felt comfortable administering an anesthetic with the FAM. A new anesthesia machine for the field will have agent-specific vaporizers available for at least halothane and isoflurane.

A common funnel port is provided on the side of the vaporizer with a liquid level sight tube. Under the vaporizer are found a drain, a spigot, and a plug (see Figure 7-33). The manufacturer recommends rinsing the vaporizer, first with hot water and then with ethyl alcohol, after one agent has been drained and a different agent is to be added. Gas from the metabolic oxygen and nitrous oxide flowmeters mix prior to entering the vaporizer housing and do not enter the vaporizer at any time. The oxygen from the oxygen-for-vaporizer flowmeter bubbles through the liquid anesthetic, and both the oxygen and anesthetic vapor mix with the metabolic oxy-

**Fig. 7-35.** The Ohio Verni-Trol anesthetic vaporizer-flow calculator is attached to the inside of the wall of the bottom case of the Field Anesthesia Machine (FAM) Model 885A. The calculator is positioned to calculate the parameters to deliver approximately 1.3% halothane to the breathing circuit at a liquid anesthetic temperature of 20°C, a barometric pressure of 760 mm Hg, an oxygen-for-vaporizer flowmeter setting of 150 cc/min, and a metabolic oxygen flowmeter setting of 5 L/min. Find the bar for HALOTHANE; note that the center of the hairline crosses the 20°C mark (all agent markings are in °C) and that the outer end of the hairline crosses the 150 cc/min mark. Next, read the desired concentration (1.3%, in this case) and the total flow immediately below the concentration (5 L/min). At the same setting, you could give 1% halothane by increasing the total flow to 6.5 L/min or 3% halothane by decreasing the total flow to 2.2 L/min. If you wanted to induce anesthesia in a patient, using 3% halothane at a total flow of 5 L/min and the halothane in the vaporizer was at a temperature of 20°C (barometric pressure 760 mm Hg), you would have to set the oxygen-for-vaporizer flow rate to 320 cc/min. Instructions for use are printed on the calculator. The accuracy of output is reasonable for clinical anesthesia. Remember: each time the metabolic oxygen flows change (eg, induction to maintenance) or the anesthetic liquid temperature changes, an adjustment must be made in the flow rate of oxygen through the vaporizer.

gen and nitrous oxide in the common gas outlet (see Figure 7-27). An oxygen sensor tee is connected to the vaporizer port (see Figure 7-14), and the inspiratory breathing circuit is attached to one limb of the tee and the oxygen sensor housing is attached to the other limb.

The FAM Model 885 vaporizer is well designed, versatile, functional, and safe in the hands of anesthesia providers who are familiar with how it works.

### Breathing Circuit

The circuit has a breathing-circuit pressure gauge, an oxygen monitor, an oxygen flush valve, and a nonadjustable pressure-relief valve (which releases gases to the atmosphere if the circuit pressure exceeds 60–80 mm Hg) (see Figures 7-27 and 7-31). The adult circuit has, in addition, an adjustable pressure-limiting valve (ie, the pop-off valve), a 3-L rebreathing bag, two one-way valves, two corrugated breathing tubes, a scavenger, a carbon dioxide absorber, a Y-piece, an elbow, and an adult's face mask (see Figure 7-27 and Figure 7-36). The pediatric partial nonrebreathing circuit is attached to the vaporizer port and has a tee connector, a breathing tube, a 1-L rebreathing bag, a one-way scavenger valve, and a child's face mask (Figures 7-37 and 7-38). When using the pediatric circuit, it is essential to close the pop-off valve to prevent the loss of gases to the atmosphere.

### Oxygen Flush Valve

The oxygen flush valve is mounted in front of the flowmeter manifold, behind the breathing pressure gauge, and between the flowmeter control knobs for metabolic oxygen and oxygen-for-vaporizer (Figure 7-39). The valve is identified by a white semicircular label with the words OXYGEN FLUSH printed in black letters. When the anesthesia provider presses down on the oxygen flush valve, the spring pressure holding a ball valve against a valve seat is counteracted, and oxygen is allowed to flow into the breathing circuit at a flow rate of approximately 40 L/min (Figure 7-40). Releasing the pressure on the button allows the spring to reseal the ball valve.

### Carbon Dioxide Absorber

A standard two-chamber carbon dioxide absorber is positioned beneath the control head (see Figure 7-12 and Figure 7-41). Once the chambers are filled with carbon dioxide-absorbent granules, the unit is secured with a clamping knob. If the clamping

knob is tightened excessively, the chamber wall can be warped, causing leaks. An absorber drain plug is located on the bottom of the unit.

Carbon dioxide-absorbent granules react irreversibly with carbon dioxide. Sodasorb (manufactured by W. R. Grace, Lexington, Mass.), a mixture of hydrated lime, sodium hydroxide, potassium hydroxide, and inert materials, reacts with carbon dioxide according to the following equations:

1.  $\text{CO}_2 + \text{H}_2\text{O} \rightleftharpoons \text{H}_2\text{CO}_3$
2.  $2\text{H}_2\text{CO}_3 + 2\text{NaOH} + 2\text{KOH} \longrightarrow \text{Na}_2\text{CO}_3 + \text{K}_2\text{CO}_3 + 4\text{H}_2\text{O} + \text{Heat}$
3.  $2\text{Na}_2\text{CO}_3 + 2\text{Ca}(\text{OH})_2 + \text{K}_2\text{CO}_3 \longrightarrow 2\text{CaCO}_3 + 2\text{NaOH} + 2\text{KOH} + \text{Heat}$

The net reaction can be expressed as follows:

4.  $\text{Ca}(\text{OH})_2 + \text{CO}_2 \longrightarrow \text{CaCO}_3 + \text{H}_2\text{O} + \text{Heat}$



**Fig. 7-36.** The Field Anesthesia Machine (FAM) Model 885A is configured with an adult breathing circuit. A corrugated hose is attached to the scavenger port of the pop-off valve. The inspiratory limb of the breathing circuit is attached to the outlet port near the vaporizer, and the expiratory limb is attached to the inlet port near the exhalation valve. Photograph: Printed with permission from Ohmeda, Inc, Madison, Wis.

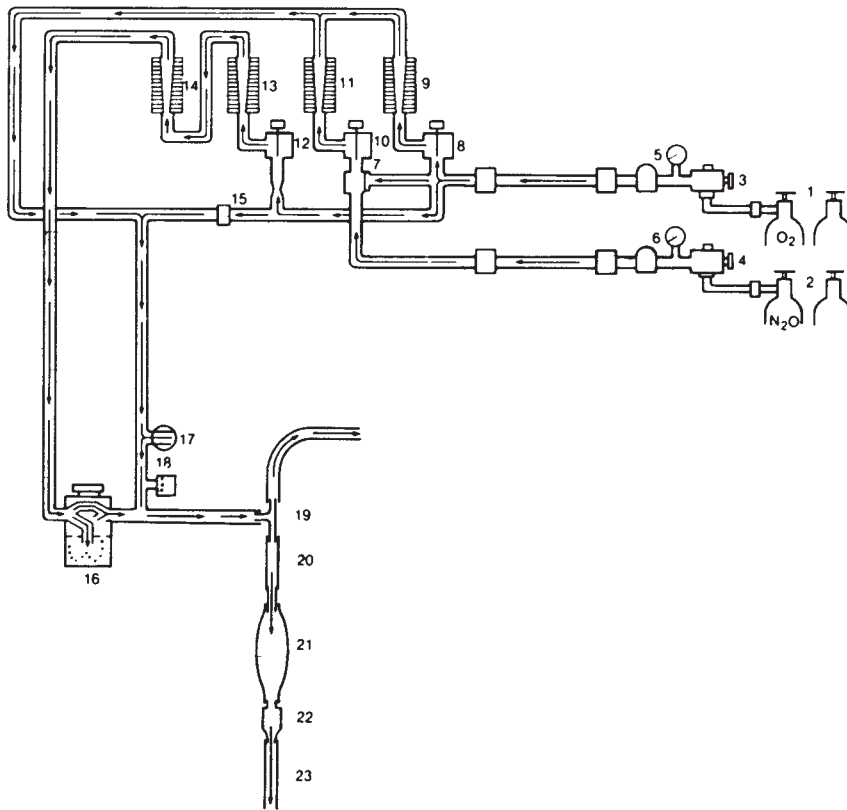


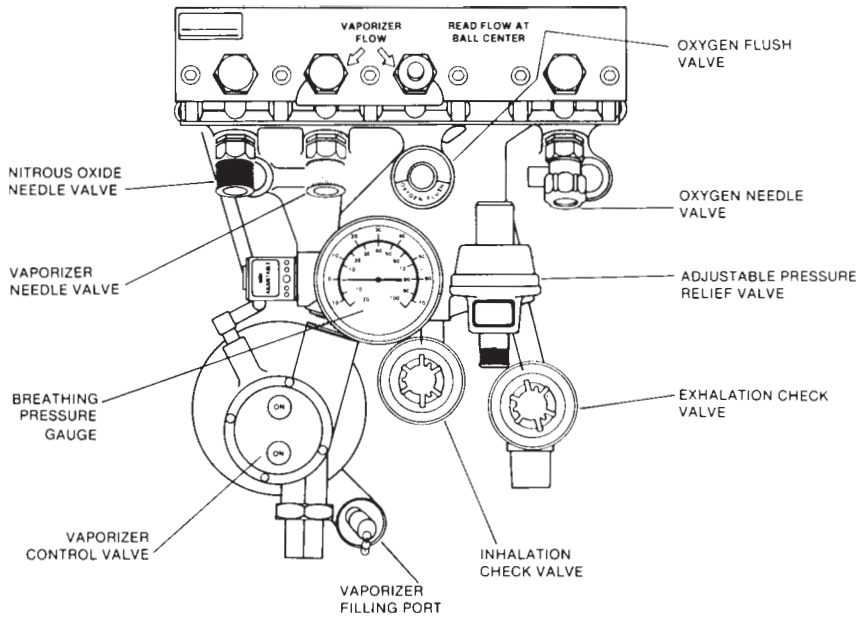
Fig. 7-37. A schematic drawing of the pediatric nonrebreathing circuit. The circuit is the same as the adult system in Fig. 7-14 except that the mixed gases do not recirculate. Mixed gases enter the tee connector (19) and flow through a short tube (20) into the rebreathing bag (21). Squeezing the rebreathing bag forces the mixed gases into the patient. Exhaled gases pass through the rebreathing bag, the scavenger valve (22), and out the gas-evacuation tubing. Low-flow rates are associated with partial rebreathing. The pop-off valve must be closed when using the pediatric circuit to prevent significant loss of gases to the atmosphere. Drawing: Printed with permission from Ohmeda, Inc, Madison, Wis.

The granules most frequently used in the United States have been Sodasorb, SODALIME USP/NF (manufactured in England by Molecular Products, Ltd.; distributed in the United States by Puritan-Bennett, Lenexa, Kan.), and Baralyme (manufactured by Allied Healthcare Products, Inc., St. Louis, Mo.). Table 7-1 compares some of the basic characteristics of the three granules. Figures 7-42 and 7-43 illustrate the differences in the three granules' absorption of carbon dioxide. Granules are provided in different kinds of packaging (Figure 7-44).

Carbon dioxide-absorbent granules are imbedded with ethyl violet, an indicator dye, which changes from white to purple at pH 10.3. Absorp-



Fig. 7-38. Field Anesthesia Machine (FAM) Model 885A configured with a pediatric nonrebreathing circuit. Fresh gases flow from the outlet port near the vaporizer to the tee of the pediatric nonrebreathing circuit. The pop-off valve of the FAM is closed to prevent gas escaping to the atmosphere. Scavenged gases leave the tip of the rebreathing bag and flow into a corrugated hose. Photograph: Printed with permission from Ohmeda, Inc, Madison, Wis.

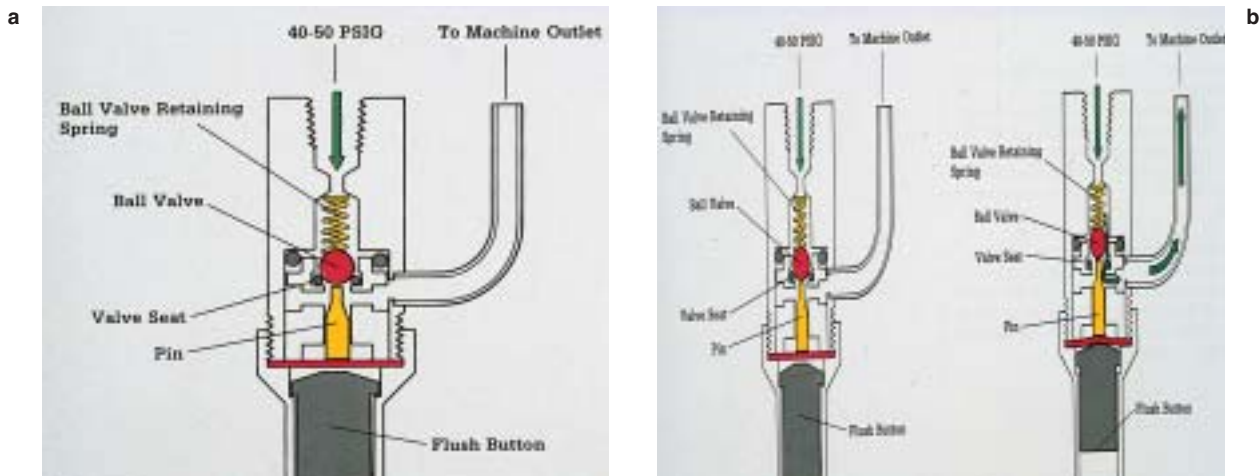


**Fig. 7-39.** Diagram of the top view of the Field Anesthesia Machine (FAM) Model 885A showing the position of the oxygen flush valve. Note the fluted oxygen needle valve, the adjustable pressure-limiting (pop-off) valve, and the two breathing-circuit check valves. The breathing-pressure gauge is in the horizontal position, making it somewhat difficult to read. Two orifices in the vaporizer control valve read ON. The nonadjustable pressure-relief valve can be seen immediately adjacent to and to the left of the breathing-pressure gauge. Redrawn with permission from Ohmeda, Inc, Madison, Wis.

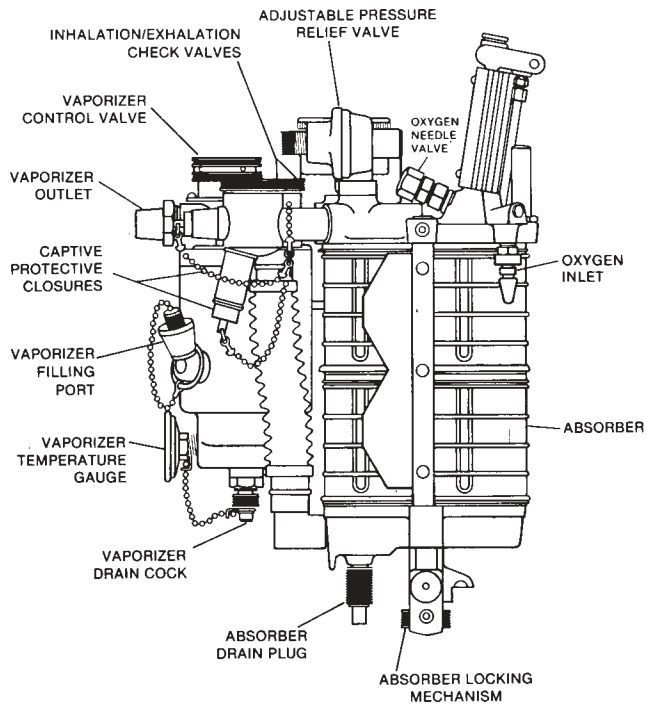
tion of carbon dioxide is not the same throughout the canister. Figure 7-45 depicts the zones of absorption; the granules immediately adjacent to and along the top encounter carbon dioxide first. Once the granules are purple, their structures are permanently changed and they should be discarded (Figure 7-46).

### Oxygen Monitor

An oxygen monitor is assembled for use with the following parts: oxygen monitor, tee, cable, oxygen sensor cartridge, mounting bracket, and batteries. The heart of the oxygen monitor is the galvanic cell sensor cartridge (Figure 7-47). Oxygen molecules



**Fig. 7-40.** How the oxygen flush valve works in the Field Anesthesia Machine (FAM) Model 885A. (a) A ball-valve retaining spring is holding the ball valve against the valve seat, preventing oxygen from escaping into the machine outlet. (b) The flush button has been pushed in, counteracting the pressure from the ball-valve retaining spring. As the pin moves, the ball valve is lifted off the valve seat, and oxygen at a pressure of 40 psig escapes into the machine outlet at 40 to 60 L / min. Photograph: Printed with permission granted by Medical Systems Division, Ohmeda, Inc, Madison, Wis.



**Fig. 7-41.** Right side of the absorber head of the Field Anesthesia Machine (FAM) Model 885A. A two-canister carbon dioxide absorber is positioned directly below the flowmeter manifold. After the absorption granules have been placed in the absorber, the absorber's locking mechanism is gently tightened to avoid leaks between the two chambers and around the gaskets. Overtightening the locking mechanism will warp the canister walls, causing permanent leaks. Protective devices used during storage are shown in place. The vaporizer's filling port, temperature gauge, and drain cock are shown. Fluid accumulating in the absorber can be drained by opening the drain plug. Redrawn with permission from Ohmeda, Inc, Madison, Wis.

**TABLE 7-1**

**COMPARISON OF COMMERCIALY AVAILABLE CARBON DIOXIDE-ABSORBENT GRANULES**

Attribute	SODALIME USP/NF* (4-8 mesh w/v granules)	Sodasorb† (4-8 mesh w/v granules)	Baralyme‡ (4-8 mesh w/v agglomerates)
Moisture (%)	16.3	14.7	14.4
NaOH content (%)	3.01	0.82	0.3
KOH content (%)	0.01	2.1	3.3
Bulk density (g/mL)	0.82	0.83	0.97
Attrition (%)	92.7	95.2	94.1
Crush strength (%)	91.9	94.1	90.5
Hardness (%)	96.2	90.1	89.0
Mesh analysis:			
> 8 mm	0	0	0
4.75-8 mm	0.9	1.7	5.9
2.36-4.75 mm	89.1	89.9	87.9
0.42-2.36 mm	9.4	7.3	5.2
< 0.42 mm	0.6	1.1	1.0

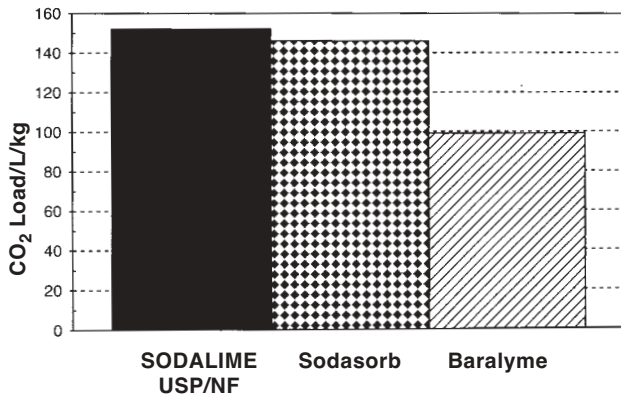
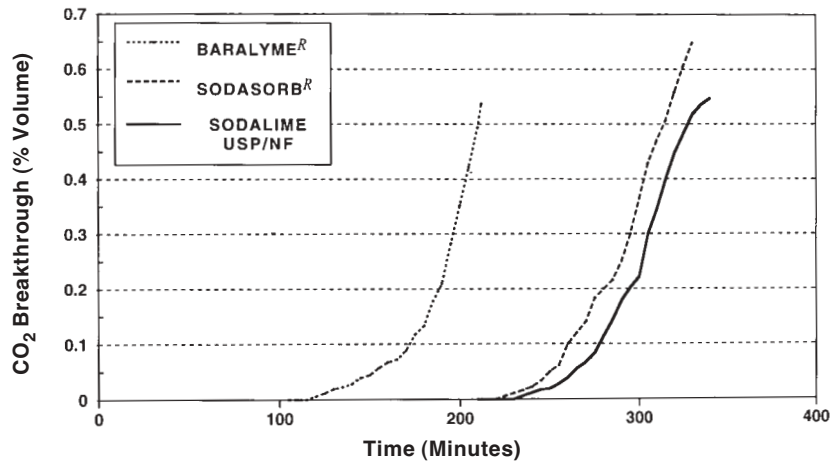
\*Manufactured by Molecular Products, Ltd (England); distributed in the US by Puritan-Bennett, Lenexa, Kan

†Manufactured by WR Grace, Lexington, Mass

‡Manufactured by Allied Healthcare, St Louis, Mo

Information provided by Puritan-Bennett Corporation, Lenexa, Kan, distributors of SODALIME USP/NF.

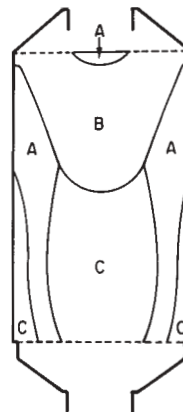
**Fig. 7-42.** Length-of-life comparison of carbon dioxide-absorbent granules. A closed-circuit test was done with 5% CO<sub>2</sub> at 500 mL • 20 breaths per minute. Carbon dioxide breakthrough occurred first with Baralyme (manufactured by Allied Healthcare, St Louis, Mo). Sodasorb (manufactured by WR Grace, Lexington, Mass) and SODALIME USP/NF (manufactured by Molecular Products, Ltd (England); distributed in the United States by Puritan-Bennett, Lenexa, Kan) absorbed more carbon dioxide than Baralyme. Information provided by Puritan-Bennett Corporation, Lenexa, Kan, distributors of SODALIME USP/NF.



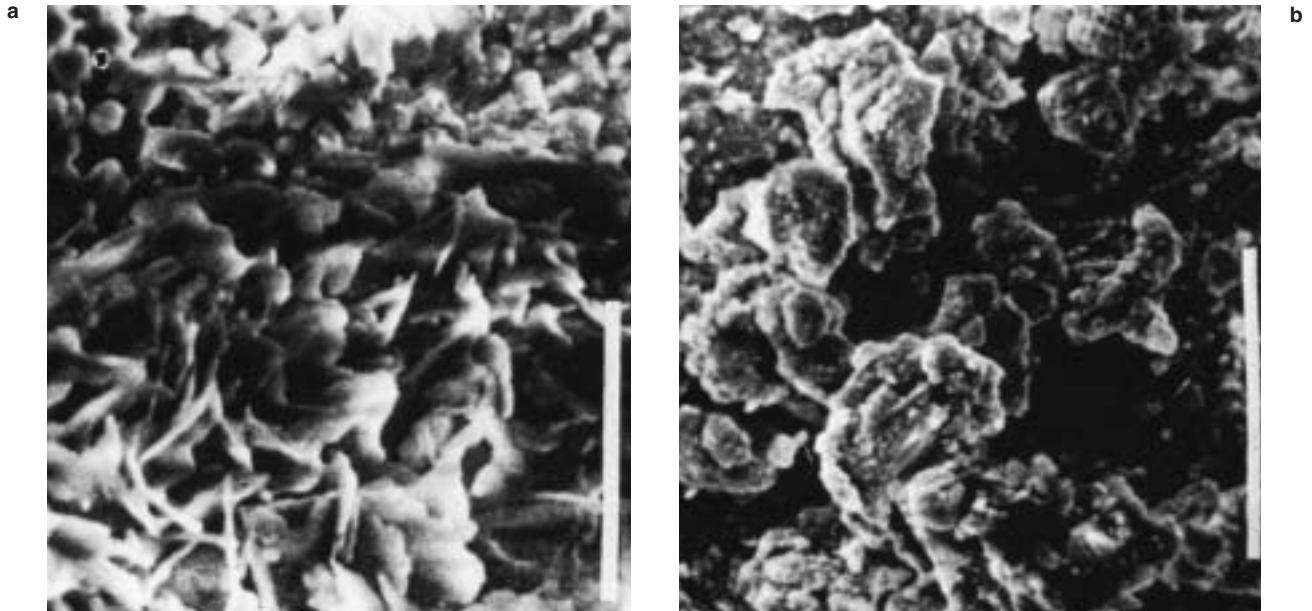
**Fig. 7-43.** Comparison of carbon dioxide loading by three absorbent granules. A closed-circuit test was done with 5% CO<sub>2</sub> at 500 mL • 20 breaths per minute. Carbon dioxide load was complete when 0.5% CO<sub>2</sub> appeared in the exit gas from the absorber. Baralyme (manufactured by Allied Healthcare, St Louis, Mo) absorbed less carbon dioxide than Sodasorb (manufactured by WR Grace, Lexington, Mass) or SODALIME USP/NF (manufactured by Molecular Products, Ltd; distributed in the US by Puritan-Bennett, Lenexa, Kans). Information provided by Puritan-Bennett Corporation, Lenexa, Kans, distributors of SODALIME USP/NF.



**Fig. 7-44.** Carbon dioxide-absorption granules can be purchased in a variety of packages. Sodasorb is available in large buckets, small sacks, and prefilled canisters. Photograph: Printed with permission of WR Grace & Co, Lexington, Mass.



**Fig. 7-45.** Zones of absorption in the carbon dioxide-absorber head. Exhaled gases enter the top of the carbon dioxide-absorber head. Granules in the A areas are rapidly depleted and change from white to purple very early. Granules in the B and C zones change slowly. Photograph: Reprinted with permission from Conry WA, Seevers MH. *Studies in carbon dioxide absorption. Anesthesiology. 1943;4:160.*



**Fig. 7-46.** (a) Normal structure of carbon dioxide-absorption granules before exposure to carbon dioxide (scanning electron micrograph, original magnification  $\times 3,000$ ). (b) Carbon dioxide-absorbent granules undergo irreversible structural changes after absorbing carbon dioxide. Soda lime granules become less defined and look cokelike (scanning electron micrograph, original magnification  $\times 3,000$ ). Reprinted with permission from Sato T, Hori T, Yusa T, Fujii A. The surface structure of carbon dioxide absorbents observed with scanning electron microscopy. *Jap J Anes.* 1970;19(1):26. In Japanese.

selectively pass through a Teflon (polytetrafluoroethylene, manufactured by Du Pont Polymers, Wilmington, Del.) membrane and react with gold to produce hydroxyl ions (Figure 7-48). Hydroxyl ions then react with lead to release electrons, which create a voltage output across an external load resistor. Computer chips allow the electron flow to be displayed as the percentage of oxygen (Figure 7-49). High- and low-percentage-of-oxy-



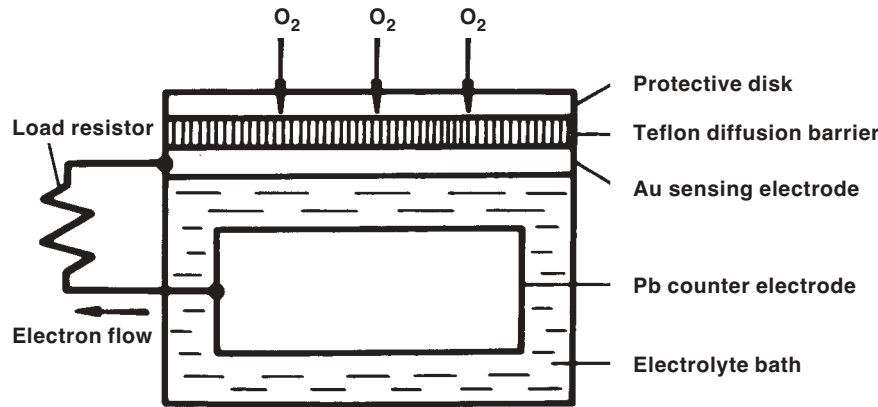
**Fig. 7-47.** An oxygen sensor housing showing the galvanic cell sensor cartridge. A cable from the housing connects the cartridge to the processor in the monitor, and the opposite end is placed in the tee of the inspiratory limb of the breathing circuit. Photograph: Printed with permission of Ohmeda, Inc, Madison, Wis.

gen alarms are included. Sensor life is exposure-dependent. Each sensor is initially packed in an inert gas and if stored under refrigeration at  $6^{\circ}\text{C} \pm 3^{\circ}\text{C}$  (CAUTION: do not freeze), can be expected to last a long time. Refrigeration is not always available in the field, so the replacement sensors should be stored (when possible) between  $18^{\circ}\text{C}$  and  $22^{\circ}\text{C}$  and between 50% and 60% relative humidity. Lifespan in use (approximately 438,000 percent hours) is determined by the time of exposure (in hours) and the concentration of oxygen (as a percentage). For example, the sensor would last 1 year if exposed to 50% oxygen but only 6 months if exposed to 100% oxygen.

After the tee is inserted in the breathing circuit between the vaporizer outlet port and the inspiratory limb of the breathing circuit, the oxygen sensor is inserted in the remaining open port of the tee. A cable connects the sensor to the monitor mounted on the bracket of the absorber head (see Figures 7-13 and 7-14).

### Checkout and Maintenance

Each FAM's *Instruction and Service Manual*<sup>1</sup> outlines in detail how to set up the machine, contains a checklist to complete prior to use, and describes how to maintain and repair the machine. In the



**Fig. 7-48.** How an oxygen galvanic cell sensor works. Oxygen molecules selectively pass through a Teflon (polytetrafluoroethylene, manufactured by Du Pont Polymers, Wilmington, Del) membrane and immediately react with gold (Au, the cathode), producing hydroxyl ions. The hydroxyl ions pass into the electrolyte bath and react with lead (Pb, the anode) to form lead oxide and release electrons. These electrons produce a current proportional to the number of oxygen molecules that are reduced at the gold cathode. An external load resistor connects the anode and the cathode. Reprinted with permission from Schreiber P. *Anesthesia Equipment, Performance, Classification and Safety*. New York, NY: Springer-Verlag; 1972: 130.

back of the manual are blow-up illustrations of the parts, and numbers for ordering parts. A videotape, *Set Up and Use of the Military Field Anesthesia Machine*,<sup>6</sup> is also available to assist the first-time user in how to give an anesthetic with the FAM.

Once the machine has been set up, it is important

to perform a checkout of the machine prior to the administration of anesthesia. The FAM will not require the same checkout as an anesthesia machine meeting the *Standard Specification for Minimum Performance and Safety Requirements for Components and Systems of Anesthesia Gas Machines*<sup>7</sup> defined by the American Society for Testing and Materials (ASTM) because it was manufactured prior to the standards. The FAM instruction manual outlines a specific checkout list covering the following areas<sup>1</sup>:

- visual inspection,
- high-pressure gas circuit check,
- low-pressure gas circuit check,
- adult breathing circuit check,
- pediatric breathing circuit check,
- the oxygen monitor,
- the gas-ratio output of metabolic oxygen and nitrous oxide,
- zeroing the breathing-circuit pressure gauge, and
- the nonadjustable pressure relief valve.

In three different places in the instruction manual, the manufacturer warns in boldface type:

**“CAUTION: No repair should ever be undertaken or attempted by anyone not having experience repairing devices of this nature.”**<sup>1(p35)</sup>

Internal repairs should not be performed in the field.



**Fig. 7-49.** An oxygen display of the percentage of oxygen in the gas mixture. Low-concentration and high-concentration alarms can be used by the anesthesia provider as conditions warrant. Photograph: Printed with permission of Ohmeda, Inc, Madison, Wis.



Simple procedures can be done by anesthesia personnel or anesthesia technicians. Soda lime should be changed when the top portion of the bottom canister begins to turn purple (exhaled gases pass into the top of the absorber and the top container is the first to be depleted). Check valves must be kept clean to avoid sticking. The pop-off valve can be dismantled easily and then inspected, washed, dried, and reassembled. Surface areas need to be wiped regularly with a damp cloth to keep dirt and grime from collecting. Special attention must be paid to the absorber and the rubber goods. Cloudiness on the inside of the canisters can be removed by buffing with Bon Ami (feldspar and calcite abrasive cleanser, manufactured by Faultless Starch/Bon Ami Co., Kansas City, Mo.). Anesthesia agents and oxygen take

their toll on the rubber goods; rubber gaskets and so forth should routinely be inspected and worn parts replaced. Preventive maintenance should be done at least every 4 months when the FAM is in service.

Sterilization is sometimes difficult to perform in field conditions, owing to the limited access to equipment and materials. Most of the components of the FAM can be washed with a mild alkali detergent and sterilized in a cold germicidal solution. Steam sterilization and ethylene oxide sterilization can be used, but with caution.

FAMs in storage with oxygen monitor sensors should be inspected at least once a year. FAMs without sensors should be inspected every 30 months. Records should be kept of all inspections, part replacements, and performance of preoperative checks.

### OHMEDA UNIVERSAL PORTABLE ANESTHESIA CIRCUIT

Before the discovery of anesthesia, surgery usually lasted less than 5 minutes because patients could not tolerate the pain. On October 16, 1846, William Morton performed the first public demon-

stration of anesthesia by using a draw-over vaporizer to administer ether to Gilbert Abbott.<sup>8</sup> Ether was poured onto a sponge in a glass container, later called the Morton inhaler (see Figure 31-5, in Chapter 31, *Military Anesthesia From Open-Drop Ether to Critical Care*). A wooden tube was placed in the patient's mouth and as the patient inhaled, a valve was opened, air that was pulled through the glass container picked up the ether vapor, and the induction of anesthesia began. The Morton inhaler proved to be cumbersome, inaccurate, and was soon replaced by the simplest form of draw-over vaporizer: a gauze-covered mask (see Figure 7-1).

Ether dripped onto a gauze-covered mask was widely used in the U.S. military from 1846 to the end of World War II. After World War II, anesthesia providers adopted circle systems in civilian hospitals and the use of draw-over vaporizers ended. In the Vietnam War, a few U.S. military anesthesia providers used draw-over vaporizers, loaned by the Australian Armed Forces, as a novelty. During the Falklands War, the British armed forces used the Tri-Service draw-over vaporizer (manufactured by Penlon, Ltd., Abingdon, England) with great success (Figure 7-50). This war was especially suited for a draw-over vaporizer: it was short, featured highly mobile forces, and long-standing field hospitals were not required. British anesthetists continued to praise the draw-over vaporizer via such vehicles as journal publications and medical meetings. Members of the U.S. military anesthesia community eventually became interested in the draw-over vaporizer. Basic research was done on the machine in the United States, and some military anesthesia provid-



**Fig. 7-50.** The Tri-Service draw-over vaporizer (manufactured by Penlon, Ltd, Abingdon, England) is used by the British armed forces. Atmospheric air is the primary carrying gas. The unit can be used with a mechanical ventilator, supplemental oxygen, and a self-inflating bag. Photograph: Printed with permission of Penlon Ltd, Abingdon, England.



**Fig. 7-51.** The Ohmeda Universal Portable Anesthesia Circuit (PAC) is shown assembled and ready for use. Photograph: Printed with permission of Ohmeda, Inc, Madison, Wis.

ers took draw-over vaporizers with them on volunteer humanitarian missions to the Third World.

Once Operation Desert Shield was mobilized, military anesthesia providers requested draw-over vaporizers as backup to the FAMs. The Ohmeda Universal PAC was chosen as the draw-over vaporizer for the U.S. military (Figure 7-51). Appropriate paperwork and PAC units were sent to the U.S. Food and Drug Administration (FDA) for its 510(k) approval for sale. The FDA was attuned to the needs of the military and was able to give its approval before the onset of Operation Desert Storm. This approval allowed the PAC to be sold to the military but restricted its use to wartime conditions. The manufacturer was requested to include the following statement in the PAC *Operation and Maintenance Manual*:

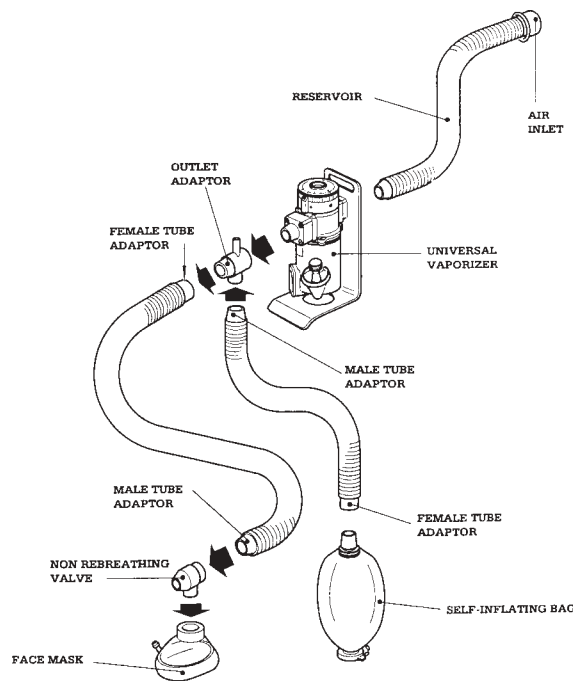
**WARNING:** The Ohmeda Universal PAC system is intended for use only in military battlefield situations where conventional closed, semi-closed continuous low flow or other more sophisticated anesthesia systems are not available. Failure to utilize a conventional anesthesia system when available significantly increases the risk of patient injury.<sup>9(p3)</sup>

PAC units were taken to Saudi Arabia and became an inventory item in the DEPMEDS system. The majority of anesthesia providers in the United States have not seen a draw-over vaporizer, are only vaguely familiar with its operating principles, and do not know how to use one safely. Learning to use a draw-over vaporizer is not complicated, but it was extremely difficult to train our military personnel during the Persian Gulf War. Anesthesia stan-

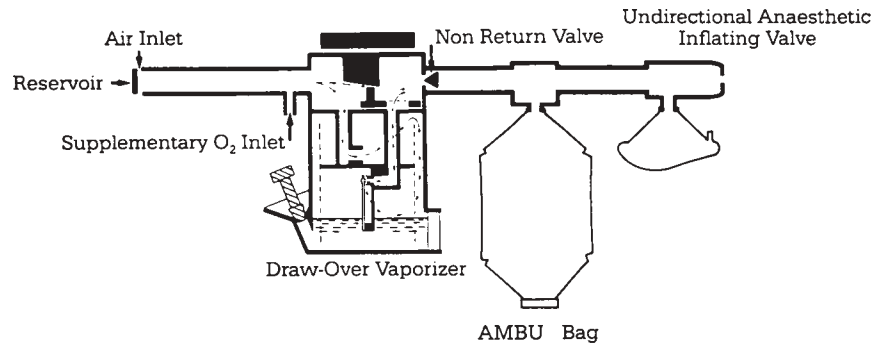
dards of care, anesthesia machine standards,<sup>7</sup> and medicolegal pressures would not allow the routine use of draw-over vaporizers in civilian hospitals and stateside military hospitals. Efforts have recently been begun to establish training sites at stateside military hospitals to provide instruction.

### Specifications and Operation

The PAC fits into a small container about the size of a small briefcase (see Figure 7-3). Figure 7-52 is a labeled diagram of the components and Figure 7-53 shows the PAC assembled. The PAC unit weighs about 5 lb and measures 7½ in. x 5½ in. x 3¾ in; the vaporizer holds 85 mL of liquid anesthetic and has



**Fig. 7-52.** Break-out view of the Ohmeda Universal Portable Anesthesia Circuit (PAC). Atmospheric air is pulled through the air inlet and the vaporizer by the recoil inflation of the self-inflating bag. The reservoir hose is a catchment area for supplemental oxygen to accumulate during the respiratory cycle. A nonrebreathing valve at the face mask keeps the air / anesthetic mixture flowing in one direction. As the self-inflating bag is squeezed, the patient's lungs are ventilated. Elastic recoil of the patient's lungs empties the exhaled gases into the room via a scavenger hose. During inflation of the self-inflating bag, air is drawn through the vaporizer, picking up anesthetic vapor and filling the self-inflating bag and connecting tube with air / anesthetic mixture. Photograph: Printed with permission of Ohmeda, Inc, Steeton, West Yorkshire, England.

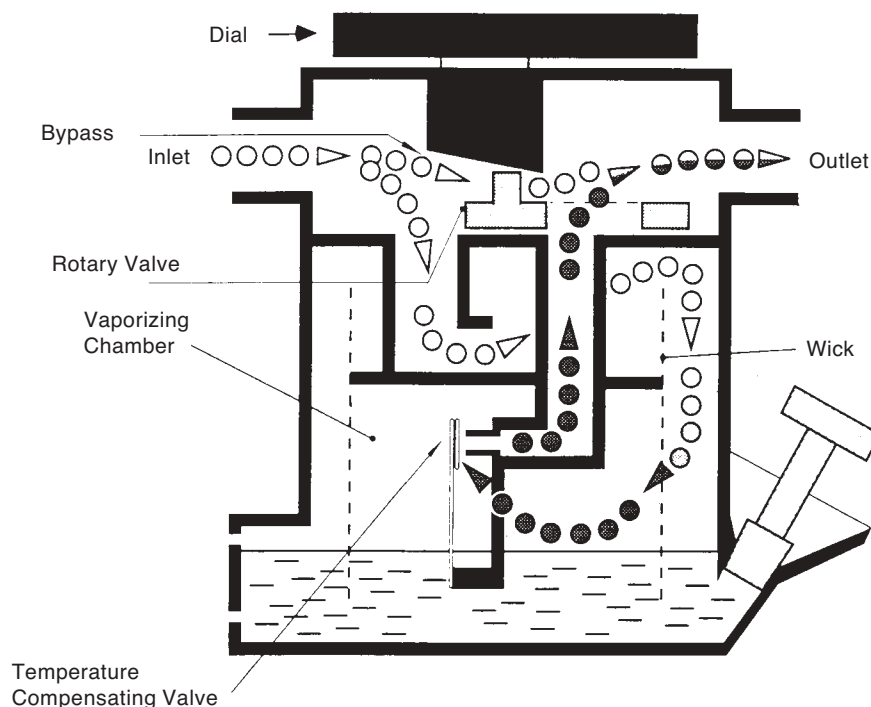


**Fig. 7-53.** Schematic of the Portable Anesthesia Circuit (PAC). Air is drawn through the air inlet into the vaporizer. A portion of the air enters the vaporizer chamber to pick up the anesthetic vapor and combine with the portion of air that bypassed the vaporizing chamber. Note the nonreturn valve at the vaporizer outlet and the nonbreathing valve at the face mask. Both function to ensure one-way airflow. A supplementary oxygen inlet is present between the air inlet and the vaporizer inlet. Oxygen can accumulate in the reservoir hose to provide enrichment of the carrier gas. Photograph: Printed with permission of Ohmeda, Inc, Steeton, West Yorkshire, England.

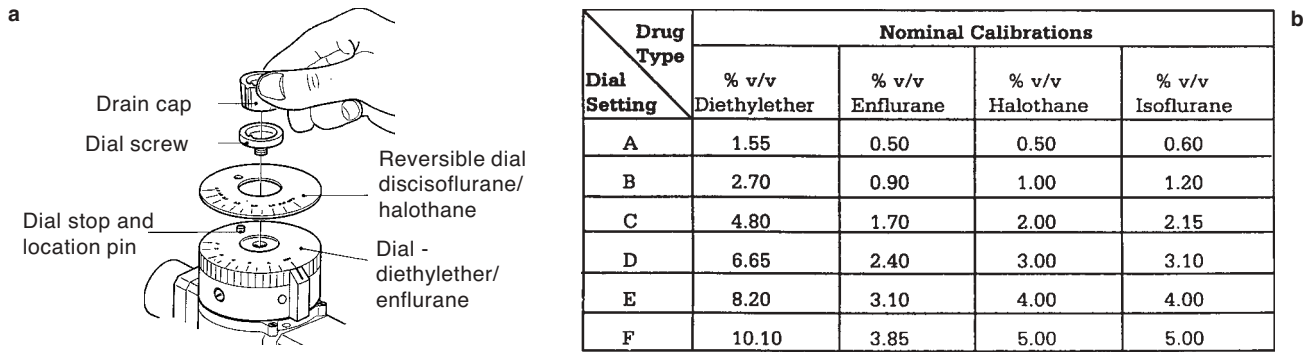
a nominal working temperature range of 18°C to 35°C (65°F–95°F).<sup>9</sup>

A one-way valve at the face mask, combined with the nonreturn valve at the vaporizer outlet, ensures the one-way movement of air from the air inlet to the face mask (Figure 7-53). Air is drawn through the PAC by the recoil negative pressure created by filling of the deflated self-inflating bag. Air flow within the vaporizer is governed by a rotary valve, which is controlled by adjusting the concentration setting dial (Figure 7-54). Two calibrated

concentration dial disks are available: isoflurane/halothane and diethyl ether/enflurane (Figure 7-55). The reversible dial disk, graduated from 0.5% to 5%, is provided as a convenient concentration dial for isoflurane/halothane. The main dial, which is attached to the vaporizer, is graduated alphabetically from A to F, and a label permanently affixed to the vaporizer gives the output for diethyl ether, enflurane, halothane, and isoflurane at each setting. As air enters the vaporizer, the vertical rotary valve divides the stream; some en-



**Fig. 7-54.** Cross section of the Portable Anesthesia Circuit (PAC) Universal vaporizer. A rotary valve is connected to the concentration dial. Changing the concentration dial setting changes both the amount of air bypassing the vaporizing chamber and the amount entering the vaporizing chamber. The vaporizer chamber holds 85 mL of anesthetic liquid; 13 mL is retained in the wick. A bimetallic strip (see Fig. 7-58) serves as a temperature-compensation valve. Photograph: Printed with permission of Ohmeda, Inc, Steeton, West Yorkshire, England.



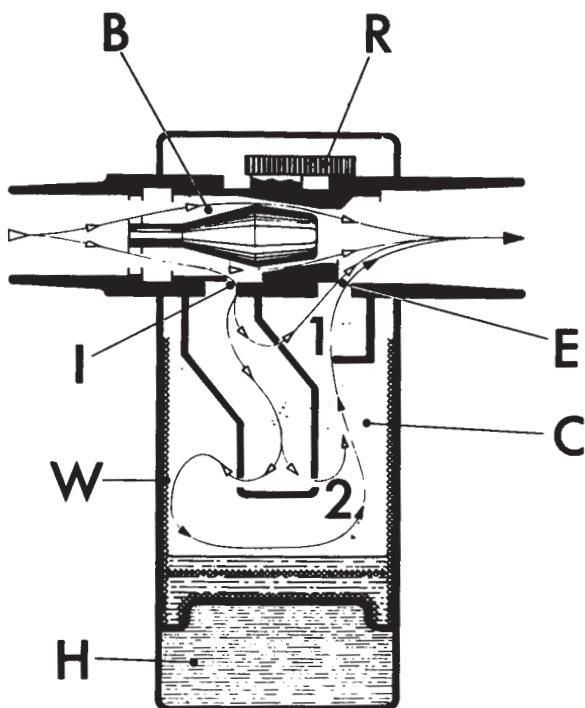
**Fig. 7-55.** The diagram (a) shows the agent-concentration dials of the Portable Anesthesia Circuit (PAC). The reversible dial disk has halothane on one side and isoflurane on the other. Gradations of concentration from 0.5% to 5% are present for both agents. The main agent-concentration dial is divided alphabetically from A to F. The tabular information (b) is affixed to the vaporizer for interpreting the concentration output for each agent. The concentration output of the main dial is graduated from A to F for diethyl ether, enflurane, halothane, and isoflurane. Filling the vaporizer with isoflurane and setting the main concentration dial at C will deliver 2.15% isoflurane at a flow rate of 4 to 6 L/min and a temperature of 20°C to 22°C. Photographs: Printed with permission of Ohmeda, Inc, Madison, Wis.

ters the vaporizer chamber and some bypasses the vaporizer. In the Tri-Service draw-over vaporizer, a sliding valve opens and closes the vapor chamber (Figure 7-56).<sup>10</sup>

As the PAC bypass gap is reduced, greater proportions of air enter the vaporizing chamber. A wick in the vaporizing chamber increases the surface area for evaporation. Heat is required for evaporation of the liquid anesthetic. A temperature

compensation valve controls the orifice where the mixture of air and anesthetic exits the vaporizing chamber to mix with the air bypassing the vaporizing chamber.

Output from the vaporizer is dependent on flow rate (tidal volume and respiratory rate), inspiratory/expiratory rate, and temperature.<sup>11</sup> High flow rates do not allow enough time for temperature compensation, so the liquid cools rapidly and out-



**Fig. 7-56.** Cross section of the Tri-Service draw-over vaporizer, which is used by the British armed forces. Air enters the vaporizer and a portion of the stream goes into the vaporizing chamber (C) through the inlet of the vapor chamber opening controlled by a sliding valve (R). The remainder of the air stream enters the bypass passage (B). Wicks (W) of stainless steel mesh increase the evaporation surface area inside the vaporizing chamber. A heat reservoir (H) filled with antifreeze liquid compensates for temperature changes. Air and anesthetic vapor pass out the vaporizing chamber outlet (E) to mix with the air coming through the bypass passage. Two different paths (1 and 2) through the vaporizing chamber provide a method of temperature and flow compensation. Photograph: Printed with permission of Penlon, Ltd, Abingdon, England.

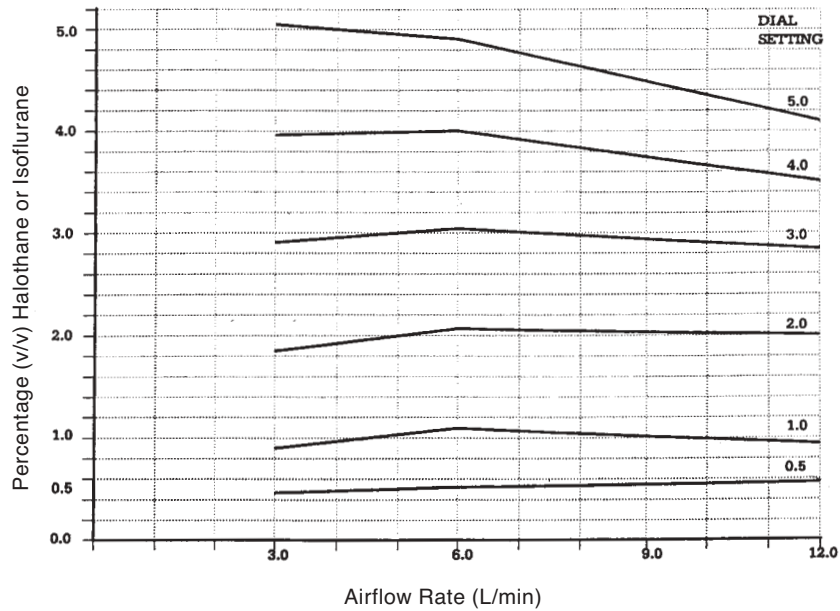


Fig. 7-57. The effect of flow rate on output concentration for halothane and isoflurane from the Portable Anesthesia Circuit (PAC). Lower concentrations are seen at higher levels of flow. The most accurate outputs are between 3 and 6 L/min. Photograph: Printed with permission of Ohmeda, Inc, Steeton, West Yorkshire, England.

put falls (Figure 7-57). Temperature compensation in the PAC is accomplished by a bimetallic strip that controls the vaporizing chamber outlet orifice (Figure 7-58). Flow rates between 4 and 6 L/min for halothane, isoflurane, and enflurane deliver concentrations close to the dial settings. If the flow rate is kept constant and the temperature of the liquid anesthetic is raised or lowered during ambient temperature changes, the output of the agent will become temperature dependent (Figure 7-59). At about 22°C, the output concentration is approximately equal to the dial setting. Vapor pressure is determined by temperature; thus, the amount of evaporated anesthetic is reduced at low temperatures and increased at high temperatures. The manufacturer

warns that “potentially hazardous excessive concentrations of anesthetic agent may occur at temperatures above 35°C (95°F).”<sup>9(p11)</sup> Tipping the vaporizer can result in unpredictable output concentrations.

An estimated hourly drug usage can be calculated by using the following formula<sup>12</sup>:

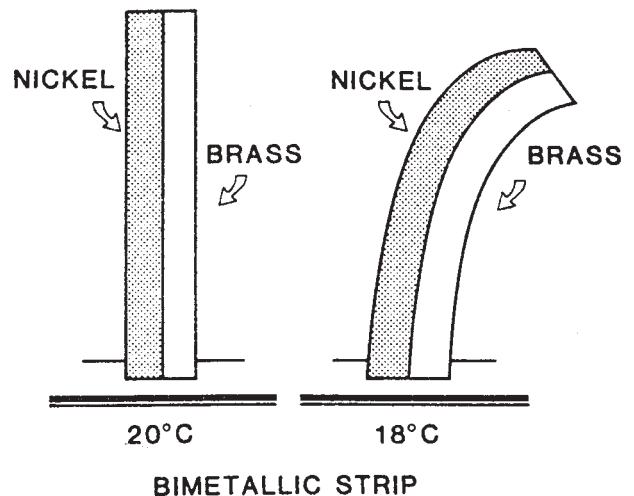
$$3 \cdot \% \cdot \text{flow (L/min)} = \text{agent usage (mL/h)}$$

For example, if the vaporizer is set to deliver 1% halothane at 5 L/min, then

$$3 \cdot 1\% \cdot 5 \text{ L/min} = 15 \text{ mL/h}$$

of halothane will be used.

Fig. 7-58. In this bimetallic strip, brass has been welded to nickel. The strip’s bending depends on the temperature and the difference in the linear expansion coefficient of brass and nickel. Temperature compensation for the Portable Anesthesia Circuit (PAC, manufactured by Ohmeda, Inc, Steeton, West Yorkshire, England) is controlled by a similar bimetallic strip at the vaporizing chamber exit (see Fig. 7-54).



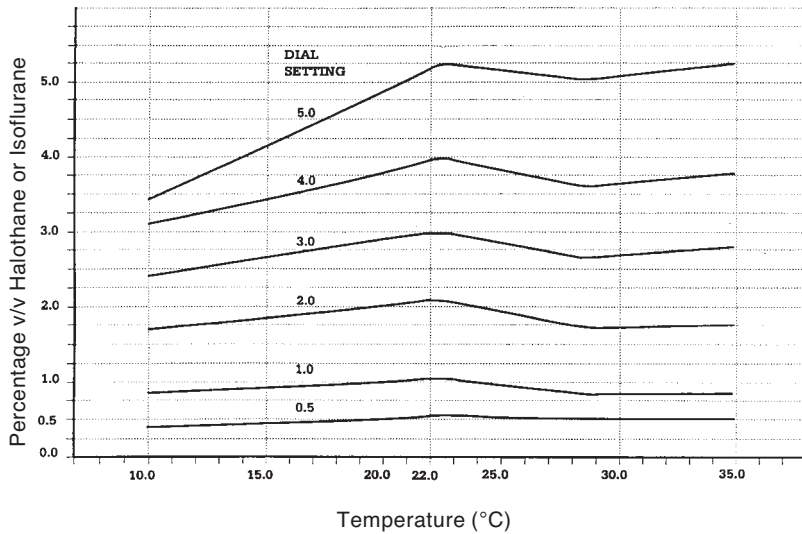


Fig. 7-59. Effect of temperature on the output concentration of halothane and isoflurane from the Portable Anesthesia Circuit (PAC). The most stable output is found between 21°C and 27°C. Photograph: Printed with permission of Ohmeda, Inc, Steeton, West Yorkshire, England.

A nipple is provided at the vaporizer inlet for connecting supplementary oxygen. Oxygen improves the safety margin for the patient and should be added whenever available. Availability of oxygen concentrators in combat areas will greatly enhance the safety of draw-over vaporizers. A ventilator and scavenger apparatus can be used with the PAC.<sup>9</sup> A training film is also available on how to use the PAC.<sup>13</sup>

### Checkout and Maintenance

A visual inspection must be made of the vaporizer, hoses, self-inflating bag, nonrebreathing valve, and any other attachments. Make sure the concentration dial on the vaporizer is the one for the liquid anesthetic agent in the vaporizer. Internal leaks can be tested by squeezing the self-inflating bag with the vaporizer in the ON position, capping the air

inlet and oxygen nipple, and releasing the self-inflating bag. The bag should not reinflate. External leaks can be detected by capping the face mask and expiratory valve ports and by squeezing the self-inflating bag. The bag should not deflate.

Clean the exterior with a damp cloth. Be sure to completely drain the vaporizer of anesthetic agent and dry the wicks before filling with a different agent. Dry the wicks by passing air through the vaporizer (minimum rate of 750 mL at 24 cycles per minute), until no vapor can be smelled at the vaporizer outlet. This drying process may take 15 to 20 minutes for isoflurane or halothane. Make sure that the vaporizer wicks are dried thoroughly when storing the vaporizer.

The manufacturer recommends yearly service if the vaporizer is used daily, servicing every 2 to 3 years with intermittent use, and every 5 years with occasional use if the vaporizer is stored dry.

## IDEAS FOR FUTURE MILITARY ANESTHESIA MACHINES

Comparison of the FAM Model 885A and the PAC with conventional anesthesia machines in state-side civilian and military hospitals finds them sorely deficient in safety features. Patient monitoring in combat areas can easily be brought up to standard with excellent portable monitors now available as off-the-shelf items (Figure 7-60). Elevating the FAM and PAC to the level expected of anesthesia machines in the United States is not possible in combat. The central problem, in the opinion of this writer, is: How do we train anesthesia providers to use the two available anesthesia machines when these machines do not meet current standards? For training purposes, many military hospitals are putting the

FAM Model 885A in the operating room with a standard anesthesia machine and transferring the machine's monitors to the FAM. Some military hospitals are even transferring the standard machine monitors to a PAC, denying that the PAC is an anesthesia machine (calling it an "apparatus"), using the PAC without the consent of the patient, and ignoring the warning in the instruction manual.<sup>14</sup>

Training for the FAM and the PAC is difficult to provide in military hospitals, since they are expected to meet the same patient-care standards as civilian hospitals. Anesthesia providers in civilian hospitals would be aghast to see a FAM 885A or a PAC in one of their operating rooms. Neither machine



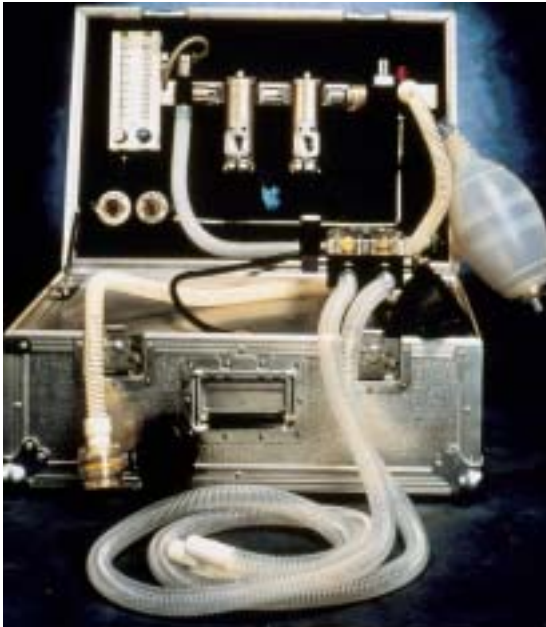
**Fig. 7-60.** PROPAC portable patient monitor. A unit this size can be fitted to monitor temperature, the electrical activity of the heart, pulse oximetry, blood pressure (direct and indirect methods), end-tidal carbon dioxide, venous pressure, and pressure from a pulmonary catheter. Photograph: Printed with permission of Protocol Systems, Inc., Beaverton, Ore.

meets the ASTM standards for anesthesia machines and the medicolegal implications of using either machine "as is" would be unthinkable. The FAM 885A, with state-of-the-art machine monitoring transferred from an anesthesia machine that meets all ASTM standards, can be used safely in the operating room if rigid protocols are established and if approval is given by the patient. Such programs are being or have been established at Naval Hospital, San Diego, California; Brooke Army Medical Center, San Antonio, Texas; and Walter Reed Army Medical Center, Washington, D. C. Exposure to FAM 885A training for anesthesia personnel in the reserves is still rather limited, but formalizing the present programs and instituting some manner of required certification may widen the scope of available training sites.

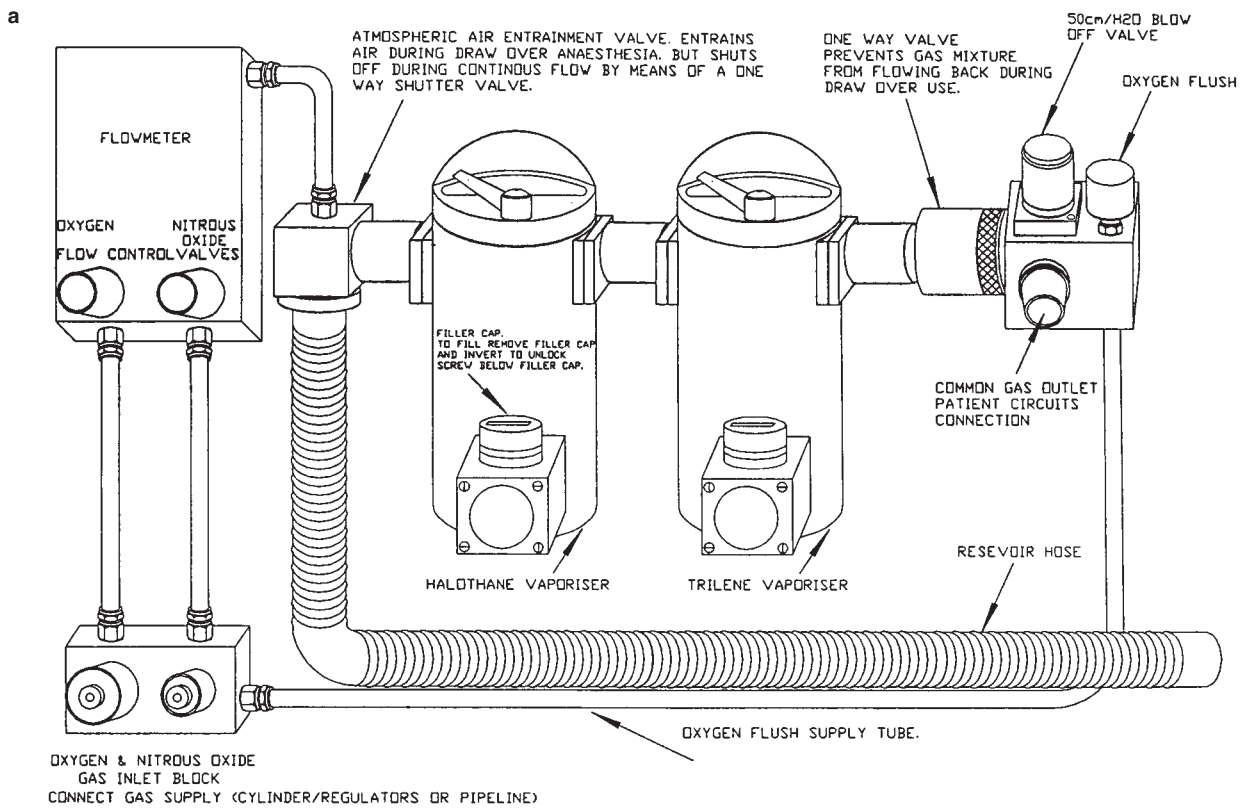
Adaptation of the PAC to present ASTM standards is not possible because the standards do not address such outdated technology. There are those within the military who have used the PAC in training programs in military hospitals in the United States in recent years by stating that the PAC is not an anesthesia machine and then using such logic to remove the medicolegal implications from the use of the machine. However, in the view of this author, *the PAC is a draw-over vaporizer anesthesia machine*, and, as such, must meet the same standards of patient care as those used in *any* hospital in the United States. A carefully prepared teaching program could allow the PAC to be used in military hospitals. The first step would be for participants to

become familiar with the PAC by reading the instruction manual, watching the videotape, listening to a didactic program, and then administering an anesthetic to animals. The second step would be to obtain permission from the risk-management department of the hospital to use the PAC in the operating room. Transferring the monitors from an ASTM-qualified anesthesia machine to the PAC and using state-of-the-art patient monitors would be essential. The third and final step would be to obtain permission from the patient. A carefully designed plan would allow the PAC to be used safely in the operating room and would allow us to train military personnel in a formalized program with some kind of certification or record of training. Some military centers are designing programs to allow restricted use of the PAC in the operating room. To push forward and use the PAC without a formalized protocol (including patient permission) is to flout the manufacturer's warning, which explicitly states that such use will significantly increase the risk to the patient. Plans are under way at the U.S. Army Medical Materiel Development Activity, Fort Detrick, Frederick, Maryland, to (a) upgrade a few of the FAM Model 885As with machine monitors and single-agent vaporizers to more closely approximate ASTM standards,<sup>7</sup> and (b) design a new FAM that will be more versatile, weigh less, and meet all the ASTM standards. A Joint Services Working Group has reviewed the characteristics of both the upgrade and a new machine. Anesthesia machine manufacturers have submitted designs for the upgrade. Money has been allocated for a military-industry cooperative effort to develop a new FAM.

The PAC might be improved by adopting some of the features of the ULCO Field Anaesthesia Apparatus (manufactured by ULCO Engineering Pty. Ltd., Marrickville, NSW, Australia) that has been developed for the Australian Armed Forces (Figure 7-61).<sup>15</sup> Its total weight is 55 lb. Versatility is the keynote feature of the apparatus. Different breathing circuits and multiple gas sources (eg, compressed-gas cylinders, pipeline gases, oxygen concentrators) can be used. Two Oxford Miniature Vaporizers (OMV, manufactured by Penlon, Ltd., Abingdon, England) connected to Tri-Service draw-over vaporizers are the heart of the apparatus (Figure 7-62) The machine can be used as a circle system or as a nonbreathing system. In the circle-system mode, a carbon dioxide absorber, and either compressed-cylinder or pipeline oxygen and/or nitrous oxide are required. When the self-inflating bag is used, the oxygen in atmospheric air is sufficient or supplemented oxygen can be added.



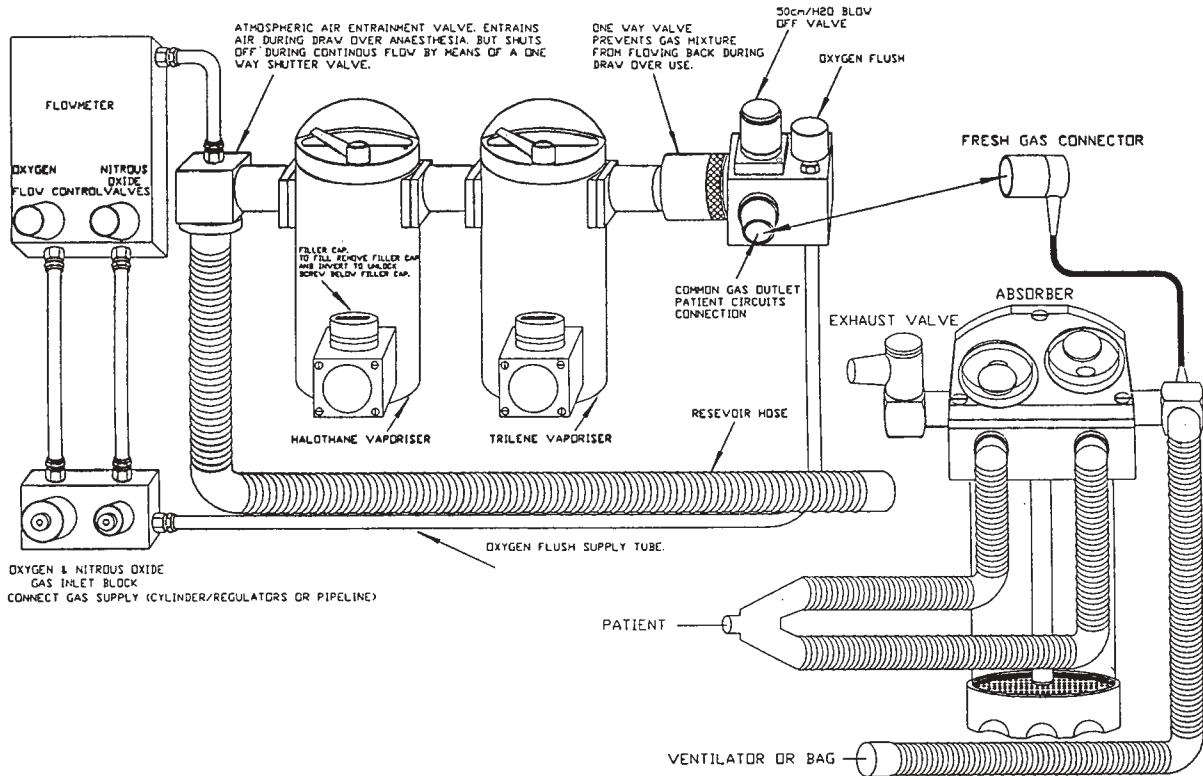
**Fig. 7-61.** The ULCO Anaesthesia Apparatus is used by the Australian Armed Forces. Two agent-specific Oxford Miniature Vaporizer (OMV) Tri-Service draw-over vaporizers (manufactured by Penlon, Ltd, Abingdon, England) are connected in series. Flowmeters are used for compressed or piped oxygen and nitrous oxide when available. A self-inflating bag converts the apparatus to a nonbreathing circuit and can be used with atmospheric air and supplemental oxygen. A small carrying case houses the 55-lb unit. A mechanical ventilator and a carbon dioxide absorber can be used with the apparatus. Photograph: Printed with permission of ULCO Engineering Pty, Ltd, Marrickville, NSW 2204, Australia.



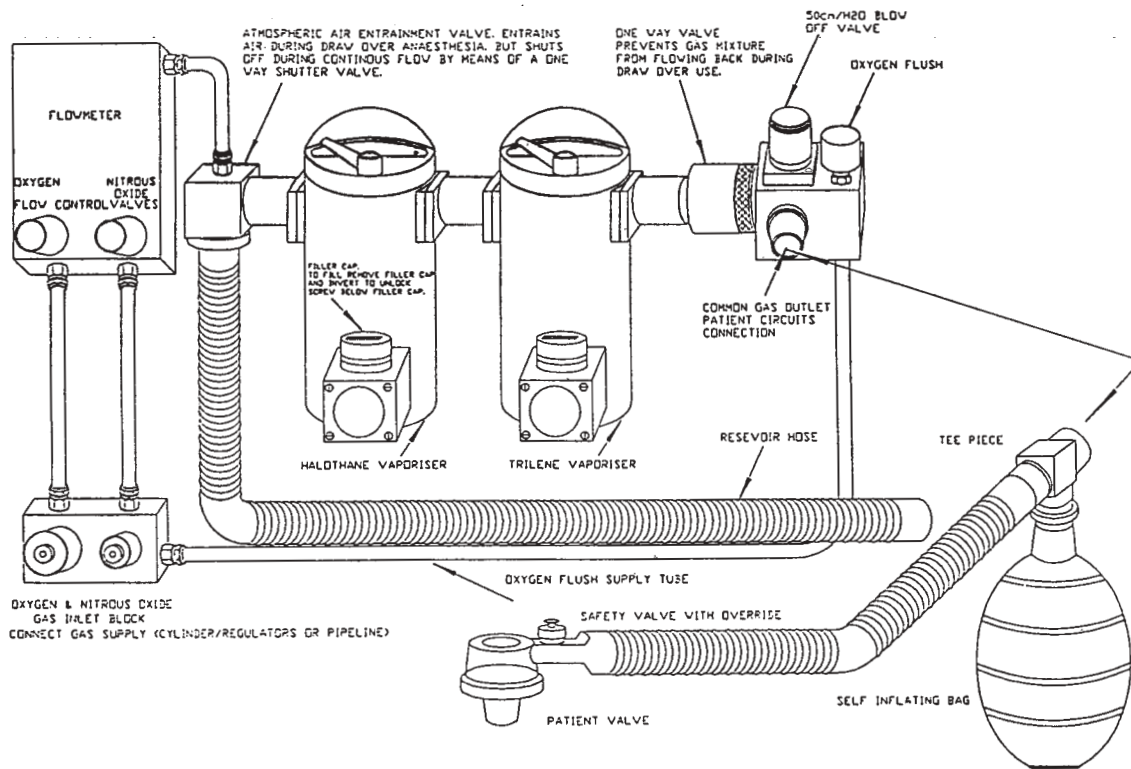
**Fig. 7-62** In the basic configuration of the ULCO Field Anaesthesia Apparatus (a), flowmeters for oxygen and nitrous oxide are used with compressed or pipeline gases when available. Two single-agent (halothane and trilene) Oxford Miniature Vaporizer (OMV) Tri-Service draw-over vaporizers (manufactured by Penlon, Ltd, Abingdon, England) are connected in series (see Figure 7-61). Atmospheric air enters the circuit when the unit is used with the self-inflating bag. A one-way valve prevents reverse flow in the circuit. An oxygen flush valve is activated when oxygen under pressure is attached. The common gas outlet is where the various circuit configurations are connected. When configured as a closed-circuit system (b), the circuit's fresh-gas connector is attached to the common gas outlet of the anesthesia apparatus. A carbon dioxide absorber with one-way valves, exhaust valve, patient breathing hoses, and connections for a ventilator or rebreathing bag are present. When configured as a non- (continued on p 173)



b



c



rebreathing circuit (c), a tee piece is attached to the common gas outlet of the anesthesia apparatus. A self-inflating bag is connected to one arm of the tee, and the patient breathing hose is attached to the other arm of the tee. A nonrebreathing valve at the connection of the face mask allows fresh gas to enter the patient's lungs and exhaled gases to exit into the room. Photographs: Printed with permission of ULCO Engineering Pty, Ltd, Marrickville, NSW 2204, Australia.

supplemented oxygen can be added.

### SUMMARY

Military anesthesia machines have been essential for the care of the wounded since the discovery of anesthesia in 1846. Each war and humanitarian effort has required military anesthesia providers to adapt to the equipment provided. At present, the military has in inventory the FAM Model 885A and

an eventual replacement with a new FAM.

the PAC anesthesia machines. Both machines are adequate for their designed task. The PAC has a limited application for rapid deployment and a short battle. Anesthesia providers and standards have outpaced the FAM Model 885A. Expectations of anesthesia providers and standards can only be met by a stop-gap measure of a FAM upgrade and

### REFERENCES

1. Ohmeda. *Instruction and Service Manual With Illustrated Parts List. Model 885A. Anesthesia Apparatus, Gas, Nitrous Oxide, Oxygen and Volatile Liquid Anesthetics, Portable 4-Cylinder Capacity.* Stock Number 0178-1683-000. Madison, Wis: Ohmeda; Sept 1990. National Stock Number 6515-01-185-8446, Defense Personnel Support Center.
2. Compressed Gas Association. *Characteristics and Safe Handling of Medical Gases.* Manual P-2. 7th ed. Arlington, Va: Compressed Gas Association, Inc; 1989.
3. Parbrook GD, Davis PD, Parbrook EO. *Basic Physics and Measurements in Anaesthesia.* 2nd ed. Norwalk, Conn: Appleton-Century-Crofts; 1986.
4. Food and Drug Administration. Medical Device Report 372985. Product: 10-134 Anesthesia Units. Common Device Name: Military Anesthesia Machine. Washington, DC: FDA; 25 March 1993.
5. DesMarteau JK. Flow through the copper kettle flowmeter. *Anesthesiology.* 1984;61:789.
6. Department of Anesthesiology, Uniformed Services University of the Health Sciences. *Set Up and Use of the Military Field Anesthesia Machine.* March 1991. Videotape; Beta, VHS, Umatic formats. Production Identification Number 503005. Bethesda, Md: Dept of Anesthesiology, USUHS; Military Medicine Education Institute. Requests, US Army, Navy, Marine Corps: Chief, Joint Visual Information Activity, ATTN; ASQNV-OJVT-ID, Tobyhanna Army Depot, Pennsylvania 18466-5100; Air Force: Commander, 1352 AVS/DOL, Bldg. 248, Norton Air Force Base, California 92409-5996.
7. American Society for Testing and Materials. *Standard Specification for Minimum Performance and Safety Requirements for Components and Systems of Anesthesia Gas Machines.* Philadelphia, Pa: ASTM; March 1989. F 1161-88.
8. William TG Morton (1819–1868), demonstrator of ether anesthesia. *JAMA.* 1965;194:190. Editorial.
9. Ohmeda. *Operation and Maintenance Manual: Ohmeda Universal PAC.* West Yorkshire, England: Ohmeda. Dec 1990. Part No. 1101-0001-000.
10. Penlon, Ltd. *User's Instruction Manual: OMV Fifty Vaporizer.* Abingdon, England: Penlon, Ltd; Oct 1989. Catalog No 51216.
11. Kingsley CP, Petty C, Olson K. Anesthesia equipment for austere conditions. In: Grande CM, ed. *Textbook of Trauma Anesthesia and Critical Care.* St. Louis, Mo: Mosby-Year Book; 1993: Chap 97.
12. Ohmeda. *PAC Range.* West Yorkshire, England: Ohmeda; 1985.
13. *Draw-over Anesthesia.* Videotape. Production No. A1908-94-002. Washington, DC: Department of Motion Picture Production, Division of Medical Audio-Visual Services, Walter Reed Army Institute of Research; 1994.
14. Casinelli PE, Reynolds PC. Adapting the Ohmeda UPAC draw-over vaporizer for use in the modern operating room. *Milit Med.* 1994;159:600–602.
15. ULCO Engineering Pty, Ltd. *Manual for ULCO Portable Anaesthesia Apparatus.* Marrickville, NSW, 2204, Australia: ULCO Engineering Pty Ltd; ca 1993.